



www.solediesel.com

Generator Control Panel

Operator's Manual

SCO 5

SCO 10

SCO 11

U_CTSC0520_EN
Revision 0

Table of contents

Table of contents.....	3
Section 1 – Introduction to the SCO.....	5
Section 2 – Technical data.....	6
Section 3 – Installation	7
3.1. SCO 5 panel installation.....	7
3.2. SCO 10 and SCO 11 panel installation	7
Section 4 – SCO 5 panel operation	8
4.1. Buttons and indicators.....	8
4.2. Display screens and page’s structure	9
4.3. Alarms, Events and History	10
4.3.1. Events list	11
4.3.2. Warnings list.....	12
4.3.3. Shutdowns list.....	12
4.4. Connections description	16
Section 5 – SCO 10 panel operation.....	17
5.1. Buttons and indicators.....	17
5.2. Display screens and pages structure	19
5.2.1. Measurement.....	19
5.2.2. Setpoint. Controller information screen	21
5.2.3. Setpoint. Maintenance hours change	22
5.2.4. History Log.....	23
5.2.5. Alarms list.....	24
5.2.6. Display contrast adjustment.....	24
5.2.7. Change language.....	25
5.3. Alarm management.....	26
5.3.1. Breaker open and cooling (BOC)	26
5.3.2. Warning (WRN)	26
5.3.3. Shut down / Apagado (SD)	26
5.3.4. Voltage phase sequence detection	26
5.4. Genset operation states.....	27
5.4.1. Engine status list.....	27
5.4.2. Electric possible events	27
Section 6 – SCO 11 panel operation.....	30
6.1. Buttons and indicators.....	30
6.2. Display screens and page’s structure	32
6.2.1. Measurement.....	32
6.2.2. Setpoint. Controller information screen	35
6.2.3. Setpoint. Maintenance hours change	36
6.2.4. History Log.....	37
6.2.5. Alarms list.....	38
6.2.6. Display contrast adjustment.....	39
6.2.7. Change language.....	39
6.3. Alarm management.....	40
6.3.1. Breaker open and cooling (BOC)	40
6.3.2. Warning (WRN)	40
6.3.3. Shut down / Apagado (SD)	40

Table of contents



6.3.4. Sensor Fail (FLS)	40
6.3.5. Voltage phase sequence detection	40
6.4. Genset operation states.....	41
6.4.1. Engine status list.....	41
6.4.2. Electric possible events	41
6.5. Connections description.....	43
Section 7 – Sensors and switches specifications	44
Section 8 – Optional equipment.....	46
8.1. Panel SCO 5 / Panel SCO 10 / SCO 11 Amperometric Pack	46
8.2. SCO 10 Second Panel Kit	46
8.3. SCO 10 Third Panel Kit.....	47
8.4. SCO 11 Second Panel Kit	48
8.5. SCO 11 Third Panel Kit.....	49
Section 9 – Electrical wiring diagrams	50
Section 10 – Overall dimensions	57

Section 1 – Introduction to the SCO

The SCO it is a control and protection panel used for generating sets; it shows the settings measured on its displays. The Unit is designed for easy use, for both installer and end-user alike.

Remote control

The SCO controller can be remotely controlled. If working on the genset, check that nobody can remotely start the engine. To be sure:

- Disconnect the control panel.
- Disconnect input REM START/STOP.
- Set the control panel in OFF mode (only SCO 10).

Symbols

Symbols used in this manual.



Grounding
point symbol



AC voltage
symbol



DC voltage
symbol

⚠ WARNING

In no case touch the terminals for voltage and current measurement!

⚠ NOTICE

Always connect grounding terminals!

Section 2 – Technical data

Technical Data			
Power supply	SCO 5	SCO 10	SCO 11
Voltage supply	8 V to 36 V DC	8 V to 36 V DC	8 V to 36 V DC
Consumption	60 mA to 12V DC	80 mA to 12V DC	2,5 W
	35 mA to 24V DC	51 mA to 24V DC	
Operation conditions			
Temperature	De -20°C to +70°C	De -20°C to +70°C	De -20°C to +70°C
Stockage temperature	De -30°C to +70°C	De -30°C to +80°C	De -30°C to +80°C
Protection front panel	IP65	IP65	IP65
Measurements			
Dimensions (Width x Height x Depth)	118 x 108 x 43 mm	180 x 120 x 55 mm	195 x 135 x 47 mm
Weight	146 grams	450 grams	450 grams
Communication			
CAN	CAN bus, 250 Kbps, max. 200 m (no insulation)	CAN bus, 250 Kbps, max. 200 m (no insulation)	CAN bus, 250 Kbps, max. 200 m (no insulation)
USB	No insulation	No insulation	No insulation
Voltage measurement			
Inputs	3 F – N voltage	3 F – N voltage	3 F – N voltage
Measurement range	0 – 277 VAC (F-N)	0 – 277 VAC (F-N)	10 – 277 VAC (F-N)
	0 – 480 VAC (F-F)	0 – 480 VAC (F-F)	10 – 480 VAC (F-F)
Current measurement			
Inputs	3 phases	3 phases	3 phases
Range	5A	5A	5A
Maximum permissible	10A	10A	10A
Binary inputs			
Number	Until 6	Until 6	Until 6
Type	Negative terminal (-)	Negative terminal (-)	Negative terminal (-)
Binary outputs			
Number	6	6	6
On towered	Positive terminal (+)	Negative terminal (-)	Negative terminal (+)
Analog inputs			
Input number	3	3	3
Type	Resistive	Resistive	Resistive

Section 3 – Installation

3.1. SCO 5 panel installation

The controller is to be mounted onto the switchboard door. Requested cutout size is 96 mm x 96mm. Use the screw holders delivered with the controller to fix the controller into the door as described on the pictures below.



Then, it is necessary to connect male connector (engine installation wire) to female connector (SCO 5).

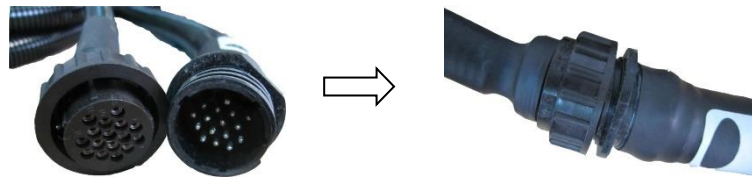

3.2. SCO 10 and SCO 11 panel installation

The controller must be mounted onto the switchboard door.

Requested cutout size is:

SCO 10: 175 mm x 115 mm.

SCO 11: 172 mm x 112 mm.

Use the screw holders delivered with the controller to fix the controller into the door as described on the pictures below.

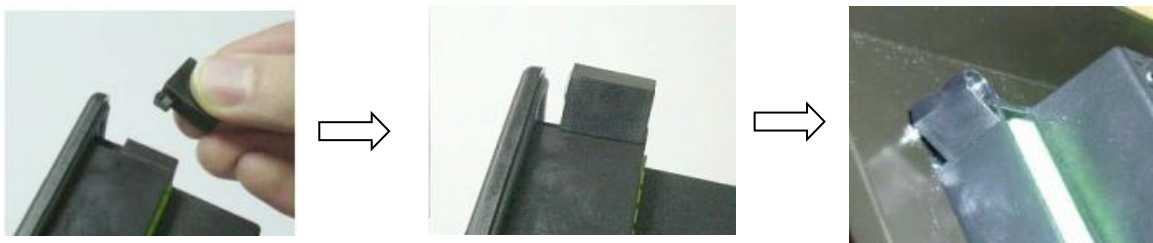





Then, it is necessary to connect male connector (engine installation wire) to female connector (SCO 5).

Section 4 – SCO 5 panel operation

4.1. Buttons and indicators





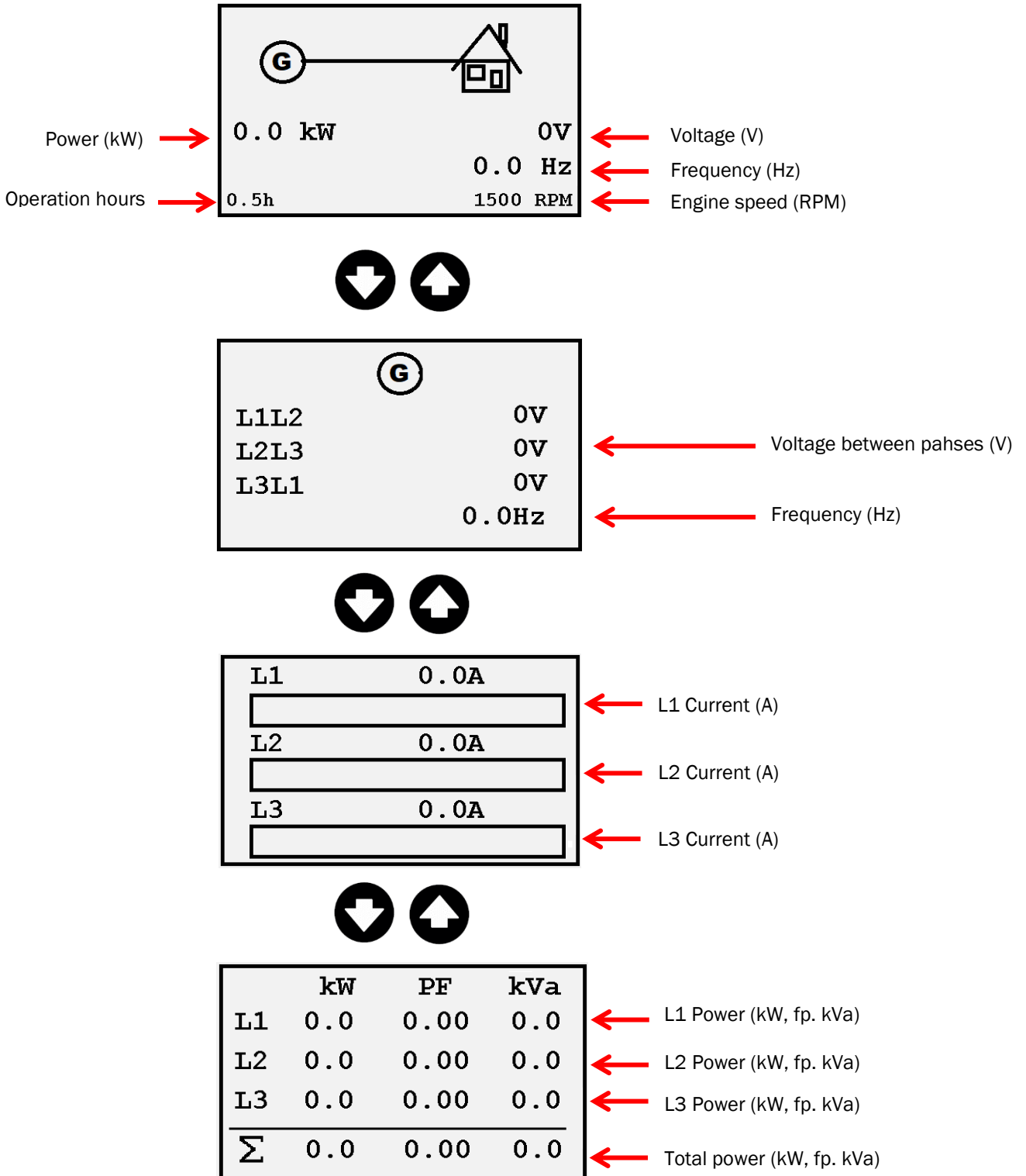

POSITION	BUTTON	DESCRIPTION
1		Graphic B/W display. 128 x 64 pixels.
2		Alarm red LED. The LED will blink when there is one or more active warning or active shutdown alarm. The LED is on when the active shutdown alarm is confirmed, and the engine can't be started.
3		STOP button. Press this button to initiate the stop sequence of the genset when engine is running - in Manual operating mode only. This button is also used to cancel changes in setup mode, to go back or to exit and for alarm confirmation.
4		AUTO button: Press this button to start checking active alarms or to enter Automatic mode,
5		START button. Works in Manual mode only. Press this button to initiate the start sequence of the engine - in Manual operating mode only. This button is also used to confirm changes in setup mode.
6		UP button. Use this button for move up or value increasing.
7		DOWN button. Use this button for move up or value decreasing.

4.2. Display screens and page's structure

The displayed information is structured into "pages" and "screens". Use buttons ▲ or ▼ to change the screen page.







	6.1 bar
	60 °C
	54%
	12.3V





- ← Oil pressure (Bar)
- ← Coolant temperature (°C)
- ← Fuel level* (%)
- ← Battery voltage (V)



	0.0 kWh
	0.0 kVArh
	0.5h

- ← Total power (kWh)
- ← Total R power (kVArh)



01		0.5
02		0.5
03		0.5
04		0.5

- ← Alarms, events and history



Return to the main screen

4.3. Alarms, Events and History









The following list shows the type of events and alarms that may appear in the history.

- Events
- Warnings
- Shutdowns
- ECU Messages (if the genset has an ECU)

Four records can be displayed simultaneously on the LCD screen. Total capacity is 15 records.

A symbol corresponding to an event appears on the display followed by a number that indicates the total number of hours of the engine in which the event occurred.

4.3.1. Events list

SYMBOL	DESCRIPTION
	Manual start: Engine was manually started by pressing button START in Manual mode.
	Remote start: Engine was remotely started via <i>input terminal 12 (BI12)</i> , if the panel is configured for this operation. The controller is in Auto mode.
	Manual stop: Engine was manually stopped by pressing button STOP in Manual mode
	Remote stop: Engine was remotely stopped via <i>input terminal 12 (BI12)</i> , if the panel is configured for this operation. The controller is in Auto mode
	Auto ON: Auto mode is activated.
	Auto OFF: Auto mode is inactivated.
	Power ON: The controller is turned on.
	Start on low battery: The engine was automatically started to recharge battery. The controller is in Auto mode and functionality is enabled.
	Stop after charging cycle: The engine was automatically stopped after battery charging cycle was performed when time set by <i>Low Battery Running Time setpoint</i> is elapsed







4.3.2. Warnings list

Active warning: When a warning occurs, 004 Alarm and 015 Common Warning outputs will close and the red LED above STOP button will blink. Warning symbol will blink in the upper-right corner of the LCD and the proper warning symbol will be displayed in the history with running hours stamp. Active warning can't be confirmed.



Inactive warning: When a warning becomes inactive, 004 Alarm and 015 Common Warning output will open, the red LED above STOP button will stop blinking, and the warning symbol on main screen will go out



SYMBOL	DESCRIPTION
	Warning maintenance: The service interval is determined by the setpoint <i>E07 Warning Maintenance</i> . The protection becomes active when the engine running hours reach this value.
	Low Battery (Charging Fail): This warning comes up if the battery voltage is lower than preset <i>E06 Battery Undervoltage</i> threshold for more than 30s. This warning also comes up when charging alternator fails.
	Low Fuel Level: This warning occurs when <i>input I21 Fuel Level Analog</i> is below 20% or <i>binary input I20 Low Fuel Level</i> is closed longer than 10s.
	External Warning 1: This warning occurs when <i>I10 External Warning 1 input</i> is activated.
	External Warning 2: This warning occurs when <i>I11 External Warning 2 input</i> is activated.
	External Warning 3: This warning occurs when <i>I12 External Warning 3 input</i> is activated.
	ECU Communication Error: This warning is activated when the ECU (if configured) is not communicating. All values from ECU show #####.

4.3.3. Shutdowns list

The controller has the following inputs and outputs (analog and binary):

Binary inputs (Negative signal “-“):

- Low oil pressure (I13)
- Remote Start/Stop or Exhaust temperature (I12) *
- High coolant temperature (I08)
- Emergency stop (I04)

Binary outputs (Positive signal “+“):

- Buzzer (O10)
- Preheating (O05)
- Fuel feed pump (O07)
- Stop solenoid (O06)
- Starter (O05)

Analog inputs:

- Oil pressure (An15)
- Coolant temperature (An14)

Active unconfirmed shutdown:

When a shutdown occurs, the Shutdown procedure will start, the red LED above STOP button blinks, the shutdown symbol will blink in the upper right corner of LCD, and the proper shutdown symbol is displayed in history with running hours stamp. For shutdown alarm confirmation press STOP button.



Active confirmed shutdown:

When an active shutdown is confirmed the red LED above the STOP button stops blinking. The record in history stays inversed with confirmation symbol at the end.



Inactive unconfirmed shutdown:











The red LED above STOP button blinks. Shutdown symbol is displayed in upper-right corner of the LCD, and proper warning symbol is displayed in history with running hours stamp. For shutdown alarm confirmation press STOP button.











Inactive confirmed shutdown:

It is possible to start engine when all shutdowns are inactive and confirmed.

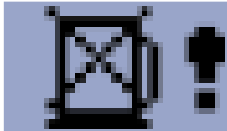

SYMBOL	DESCRIPTION
	Emergency stop: the <i>binary input (I04)</i> is activated.
	Overspeed: The protection comes active if the speed is greater than 120 % of nominal engine RPM. Actual speed value is derived from genset frequency or is sensed directly using magnetic pick-up input.
	Underspeed: Low engine RPM. This alarm will be issued when the genset is running and then stops by itself. The underspeed alarm starts to be evaluated 5 sec after successful genset start and is being evaluated all the time <i>the output O02 Fuel Solenoid</i> is active.
	Low oil pressure: Engine will stop when oil pressure drops below preset value or when the <i>binary input I13</i> is activated.
	High coolant temperature: Engine will stop when temperature of coolant exceeds the preset value or when the <i>binary input I08</i> is activated.
	External Shutdown 1: This shutdown occurs when <i>I13 External Shutdown 1</i> input is activated
	External Shutdown 2: This shutdown occurs when <i>I14 External Shutdown 2</i> input is activated.
	External Shutdown 3: This shutdown occurs when <i>I15 External Shutdown 3</i> input is activated.
	GCB Fail: Failure of genset circuit breaker.
	Generator Overvoltage: Genset will stop when output voltage exceeds the preset value.
	Generator Undervoltage: Genset will stop when output voltage drops below the preset value.

SYMBOL	DESCRIPTION
	Generator Overfrequency: The genset frequency is out of limits given by setpoints <i>G03 Generator Overfrequency Shutdown</i> and <i>G04 Generator Underfrequency Shutdown</i> .
	Generator Underfrequency: The genset frequency is out of limits given by setpoints <i>G03 Generator Overfrequency Shutdown</i> and <i>G04 Generator Underfrequency Shutdown</i> .
	Generator Overload: The genset will stop when output load exceeds the preset threshold <i>G07 Generator Overload Shutdown</i> .
	Generator Short Circuit: The genset will stop when output current exceeds the preset threshold <i>G05 Generator Short Circuit Shutdown</i> .
	Generator CCW: Rotation Incorrect genset phase sequence
	Start Fail: Genset start failed
	Stop Fail: Genset stop failed.
	Battery Flat: If the controller loses power during starting sequence due to bad battery condition, it will not try to start again and will activate this protection.
	Voltage Autodetect: If measured genset voltage doesn't correspond with predefined values for particular connection type when Autodetect value for <i>B04 Connection Type</i> is used.
	Fuel Level SD: This shutdown occurs when <i>analog input I21 Fuel Level Analog</i> is below shutdown threshold or when <i>binary input I29 Fuel Level SD</i> is activated. Both longer than 10s.

Note:

Within the contents of the control panel box, a sticker is supplied with a summary table of the most important alarms.

4.4. Connections description

	Code	Terminal	Signal type	Description	Color
Engine monitoring	I23	T15	Analog input	Oil pressure sensor	Brown
	I25	T14	Analog input	Coolant temperature sensor	Grey
	I22	T13	Binary input	Oil pressure switch	Blue
	I10	T12	Binary input	Exhaust temperature switch *	Purple
	-	T11	-	COM	Black
	O04	T10	Binary output	Alarm	No wired
	O08	T09	Binary output	Glow plugs	Green - white
	I24	T08	Binary input	Coolant temperature switch	White
	O09	T07	Binary output	Fuel feed pump	Green
	O02	T06	Binary output	Stop solenoid	Yellow
	O01	T05	Binary output	Starter signal	Pink
	I01	T04	Binary input	Emergency stop	Red
Genset monitoring	-	T27	Analog input	L1 phase voltage	Black - white
	-	T29	Analog input	L2 phase voltage	Brown - white
	-	T31	Analog input	L3 phase voltage	Grey - white
	-	T25	Analog input	N phase voltage	Blue - white
	-	T23	Analog input	L1 phase current *	Black
	-	T22	Analog input	L2 phase current *	Brown
	-	T21	Analog input	L3 phase current *	Grey
	-	T20	Analog input	COM *	Blue





*The standard installation doesn't include this connection.

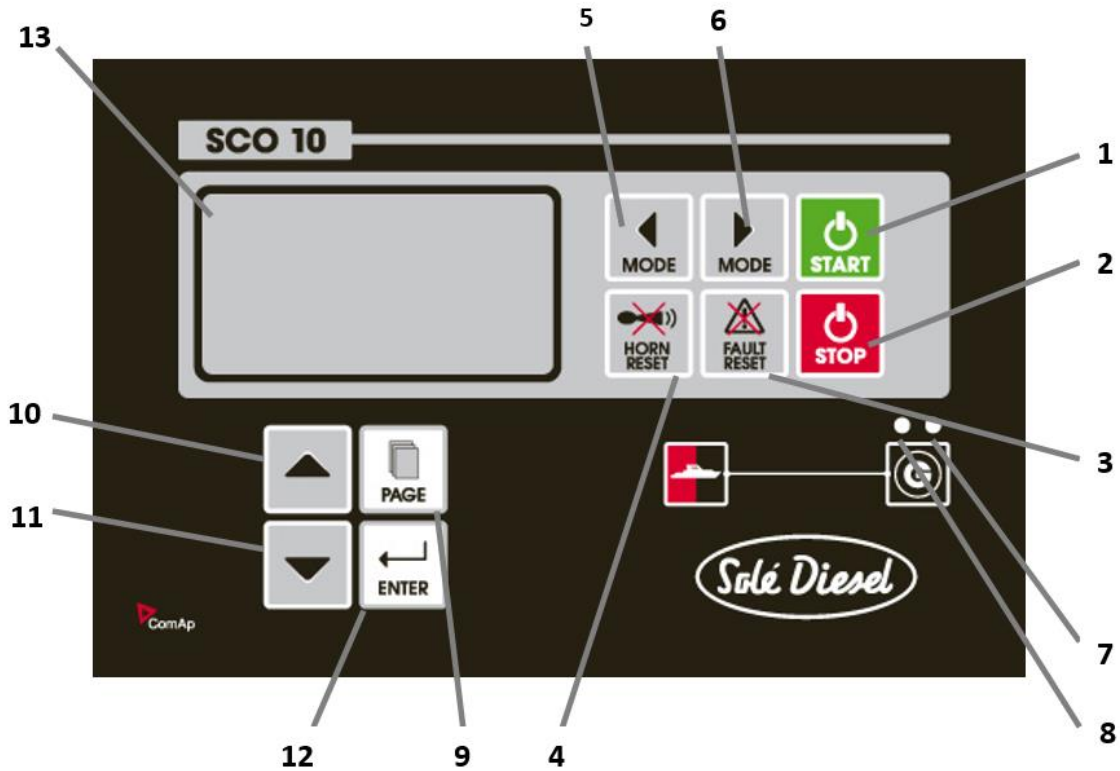

Section 5 – SCO 10 panel operation

5.1. Buttons and indicators



GENSET CONTROL BUTTONS



POSITION	BUTTON	DESCRIPTION
1		START button. Works in MAN mode only. Press this button to initiate the start sequence of the engine.
2		STOP button. Works in MAN mode only. Press this button to initiate the stop sequence of the genset. Repeated pressing or holding the button for more than 2s will cancel current phase of stop sequence (like ramping the power down or cooling) and next phase will continue.
3		FAULT RESET button. Use this button to acknowledge alarms and deactivate the horn output. Inactive alarms will disappear immediately and status of active alarms will be changed to "confirmed" so they will disappear as soon as their reasons dismiss.
4		HORN RESET button. Use this button to deactivate the horn output without acknowledging the alarms.

POSITION	BUTTON	DESCRIPTION
5		MODE LEFT button. Use this button to change the mode. The button works only if the main screen with the indicator of currently selected mode is displayed. Note: This button will not work if the controller mode is forced by one of the binary inputs Remote OFF, Remote MAN, Remote AUT.
6		MODE RIGHT button. Use this button to change the mode. The button works only if the main screen with the indicator of currently selected mode is displayed. Note: inputs Remote OFF, Remote MAN, Remote AUT.

GENSET OPERATION INDICATORS

POSITION	BUTTON	DESCRIPTION
7		Genset failure. Red LED starts flashing when genset failure occurs. After FAULT RESET button is pressed, the light steadies (if an alarm is still active) or turns off (if no alarm is active).
8		Genset voltage OK. Green LED is on if the genset voltage is present and within limits. Note: The limits for the genset voltage and frequency are given by setpoints in the Gener Protect group.

BOTONES DE VISUALIZACIÓN Y CONTROL

POSICIÓN	BOTÓN	DESCRIPCIÓN
9		Botón PAGE . Utilice este botón para ir cambiando entre páginas de visualización. Ver Section <i>Pantallas de visualización y estructura de páginas</i> bajo esta tabla para más detalles.
10		Botón ARRIBA . Utilice este botón para ir hacia arriba o aumentar un valor.
11		Botón ABAJO . Utilice este botón para ir hacia abajo o disminuir un valor.
12		ENTER button. Use this button to finish editing a setpoint or moving right in the history page.
13		Graphic B/W display, 128x64 pixels

5.2. Display screens and pages structure

The displayed information is structured into "pages" and "screens". Use PAGE button to switch over the pages.

1. The *Measurement* page consists of screens which display measured values like voltages, current, oil pressure etc., computed values like genset power, statistic data and the alarm list on the last screen.
2. The *Setpoints* page contains all setpoints organized in groups and also a special group for entering password.
3. The *History log* page shows the history log in reverse order, so the last record is displayed first.

5.2.1. Measurement

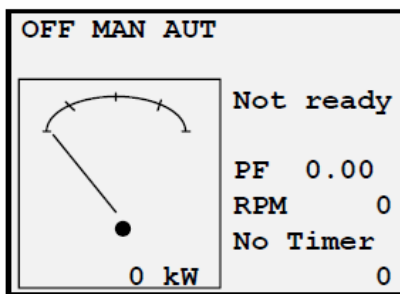

- Ready genset / No ready
- Power factor*
- RPM
- Timer seconds of each genes phase.
- Active power pointer*

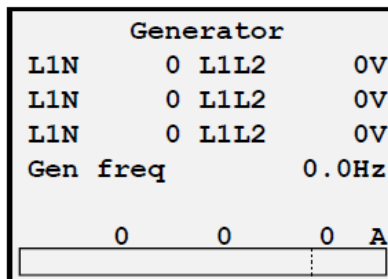

- Voltage between phases and neutral
- Voltage between different phases
- Genset frequency
- Electric current/phase current*

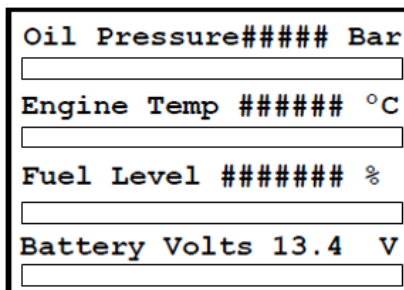

- Oil pressure
- Engine temperature (cooling)
- Fuel level
- Battery voltage

*In order to view these values, the Amperometric Pack must be installed.

Binary Inputs – Binary signals from the genset to control panel.



Bin Inputs	00000
Rem Start/Stop	0
Coolant temp.	0
Emergency Stop	0
Oil Pressure	0
Sd Override	0
Exhaust temp.	0

- **BI1:** Remote control – Start or Stop
- **BI2:** Alarm / Temperature switch (shutdown)
- **BI3:** Emergency STOP.
- **BI4:** Alarm / Pressure switch
- **BI5:** Sd Override.
- **BI6:** Exhaust gas temperature (optional kit).

Binary Outputs – Ordenes del Panel de Control al grupo.



Bin Outputs	0000
Starter	0
Fuel solenoid	0
Air valves	0
Glow plugs	0
Horn	0
Alarm	0

- **B01:** Crancking signal (start)
- **B02:** Stop solenoid, f current comes or not. Fuel Solenoid corresponds to STOP ETR
- **B03:** Air Valves: corresponds to a feed pump
- **B04:** Pre-heating glow plugs
- **B05:** Horn (free, is not wired)
- **B06:** Alarm. If the system detects an alarm (free, is not wired)



Gen-set Power			
	kW	PF	kVA
Tot	0	0.00	0
L1	0	0.00	0
L2	0	0.00	0
L3	0	0.00	0

- The left column shows the active power of each phase and total current (*if the amperometric kit is installed*).
- The middle column shows the power factor of each phase and total current (*if the amperometric kit is installed*).
- The right column shows the apparent power of each phase and total.



AlarmList	1
Emergency Stop	



If you do not understand the description of the alarm it is recommended to change the language to English, the original language. If still in doubt, contact to factory.

SCO 10 panel operation



5.2.2. Setpoint. Controller information screen

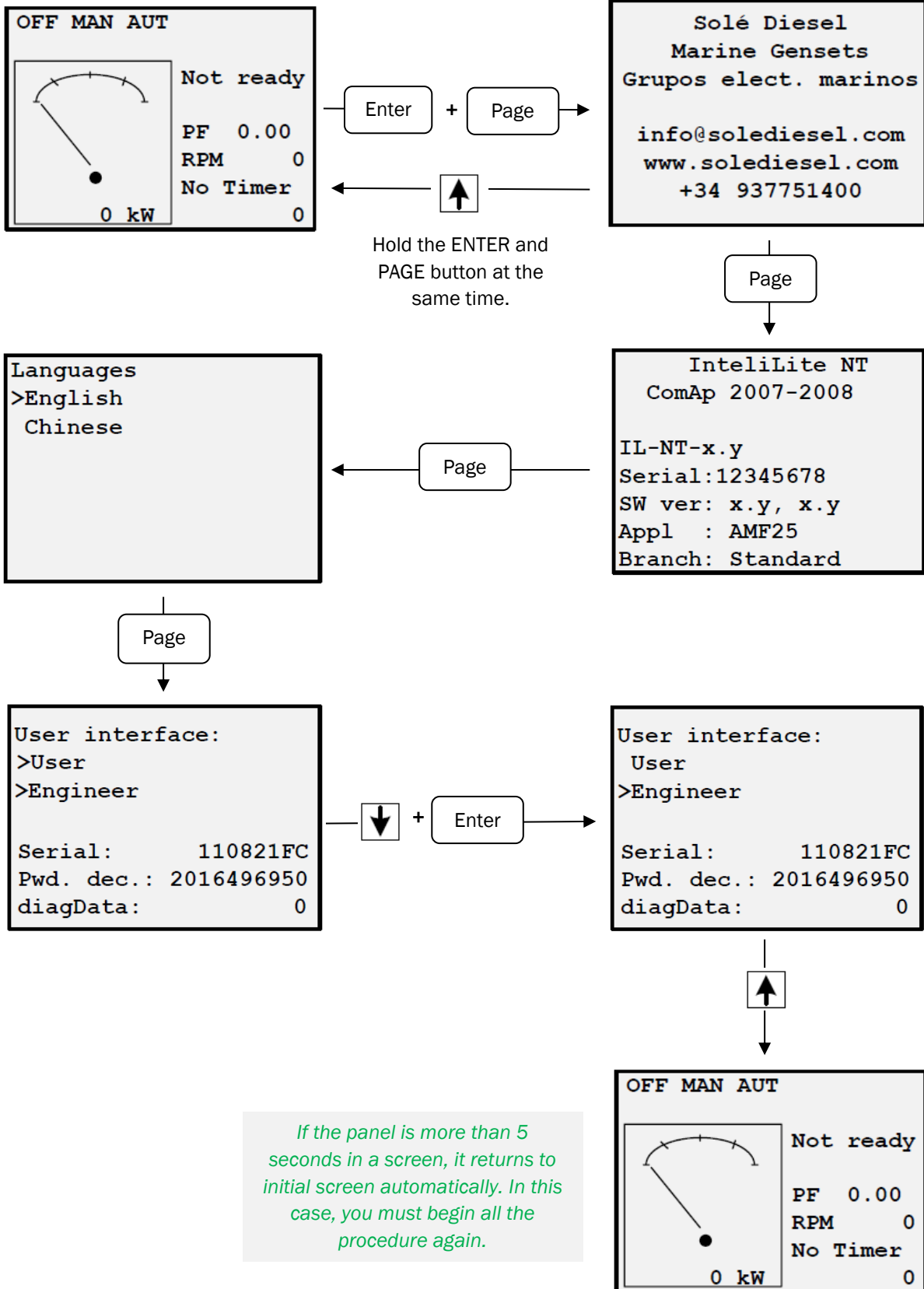

5.2.3. Setpoint. Maintenance hours change

When the following warning appears in the Alarm list screen of SCO 10: First of all you must carry out the maintenance tasks according to the Maintenance task table, attached in the end. You also can consult this information in the Warranty manual. Then, you must accept the alarm (press FAULT RESET button) and put the 200 hours to the next maintenance period, in accordance with these instructions:

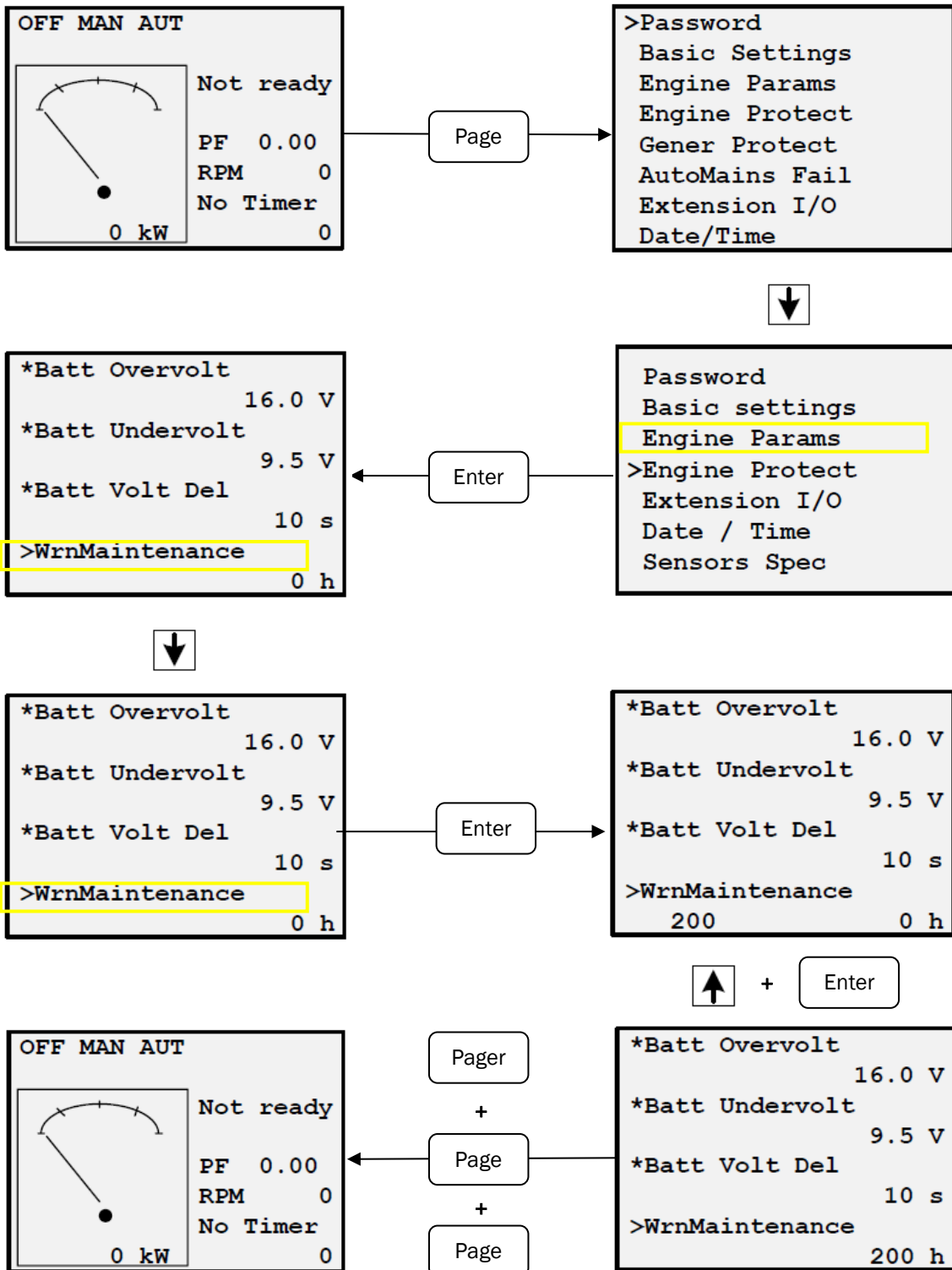

5.2.4. History Log

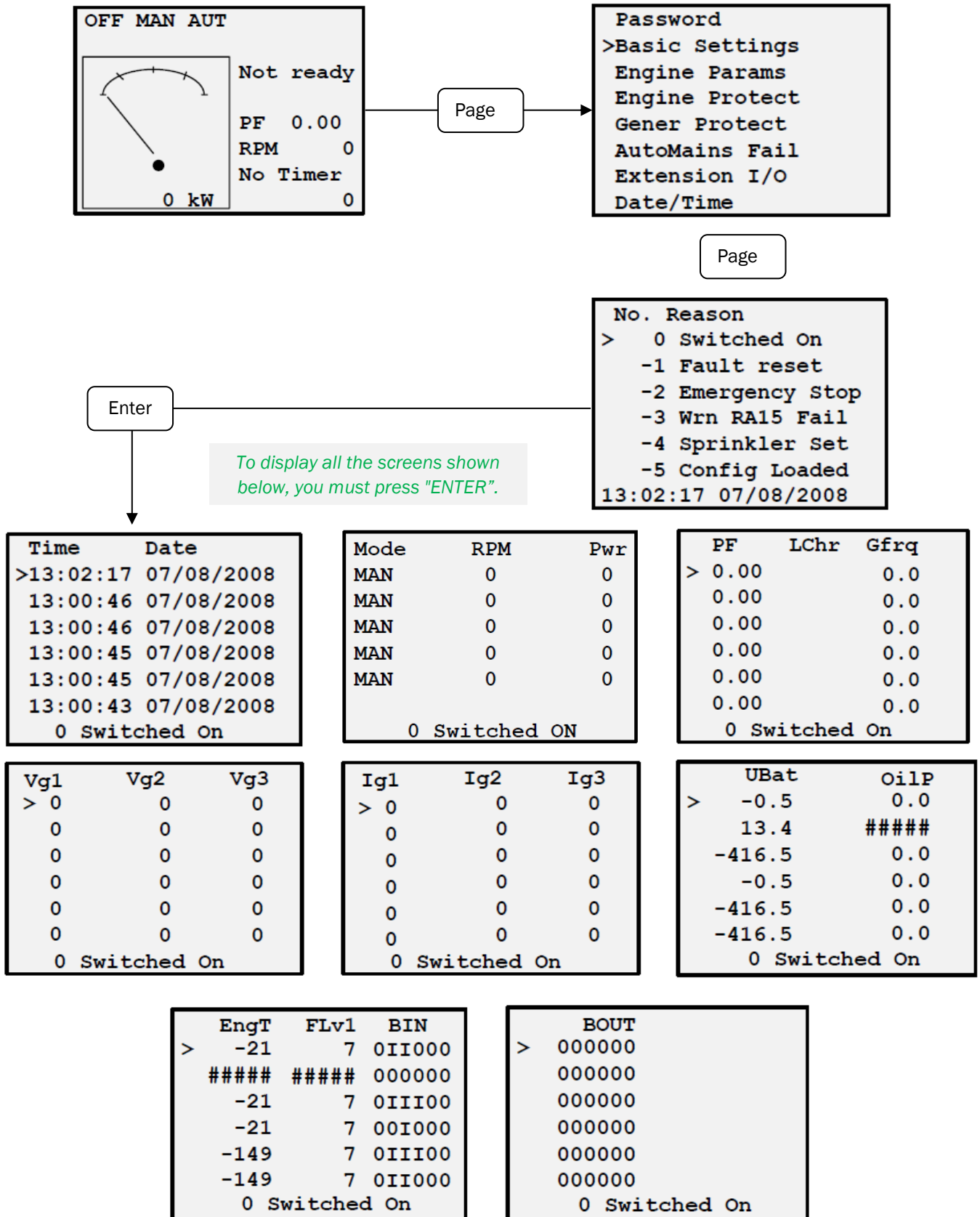

5.2.5. Alarms list

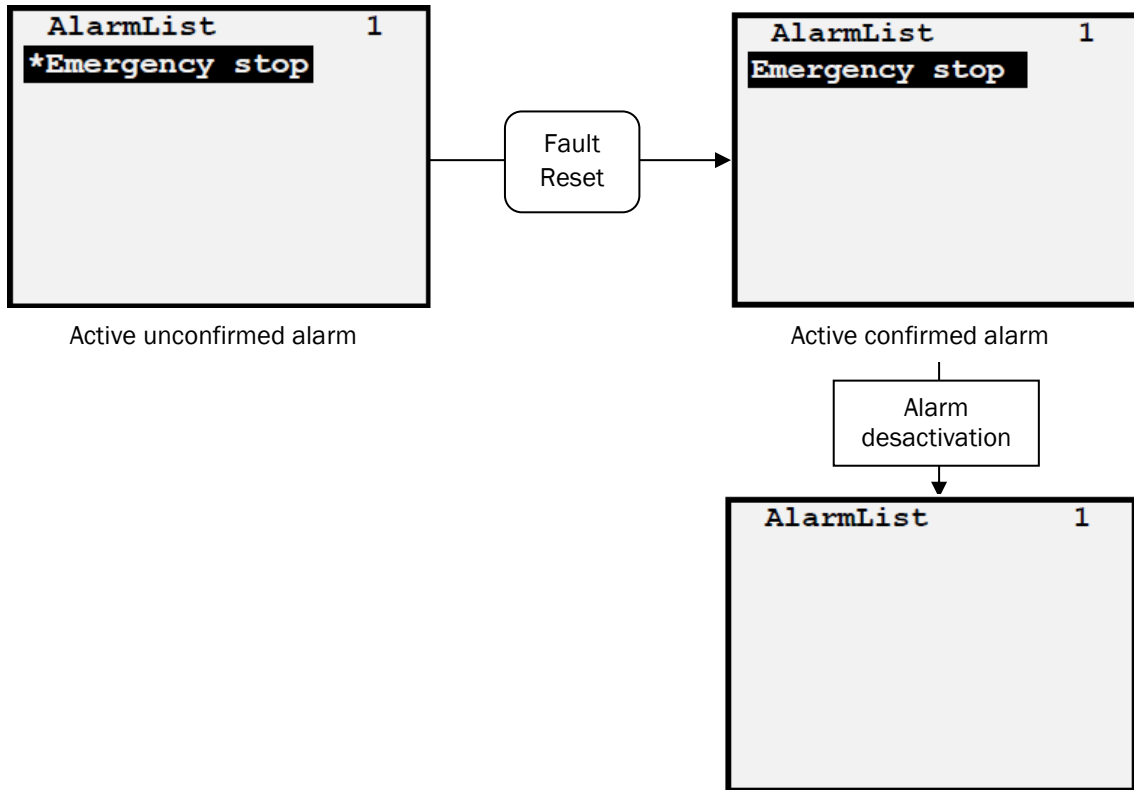

5.2.6. Display contrast adjustment

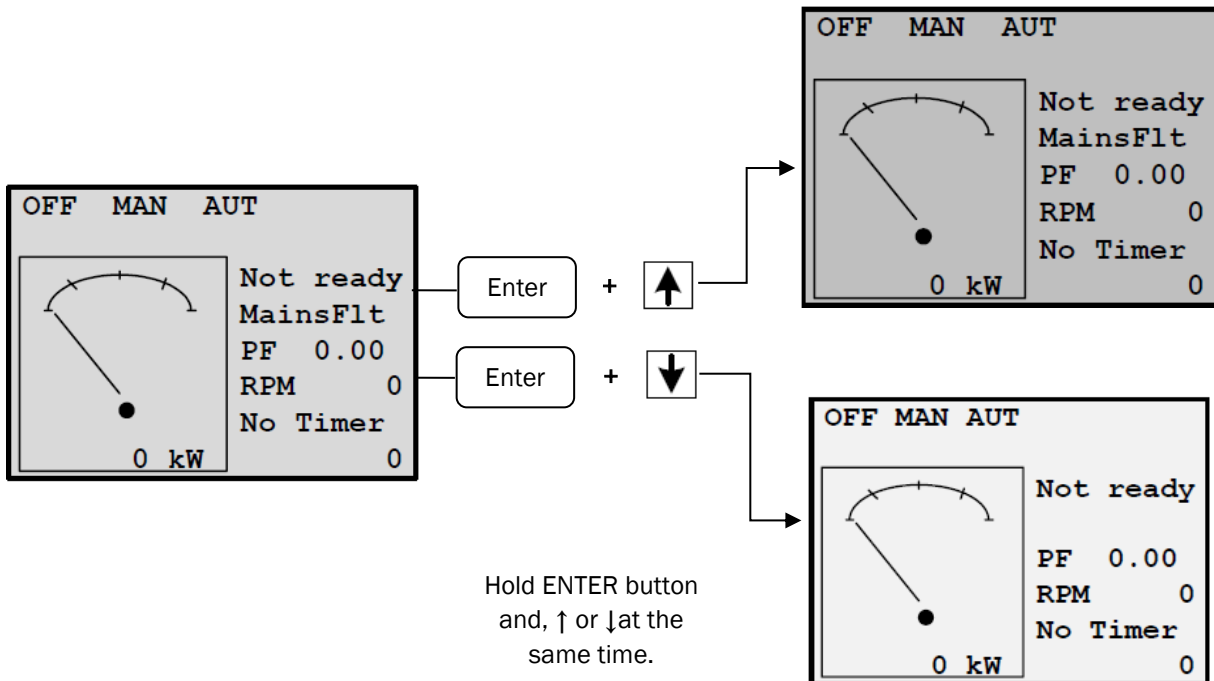

SCO 10 panel operation



5.2.7. Change language

You must follow these steps to change the panel language.

If the panel is more than 5 seconds in a screen, it returns to initial screen automatically. In this case, you must begin all the procedure again.

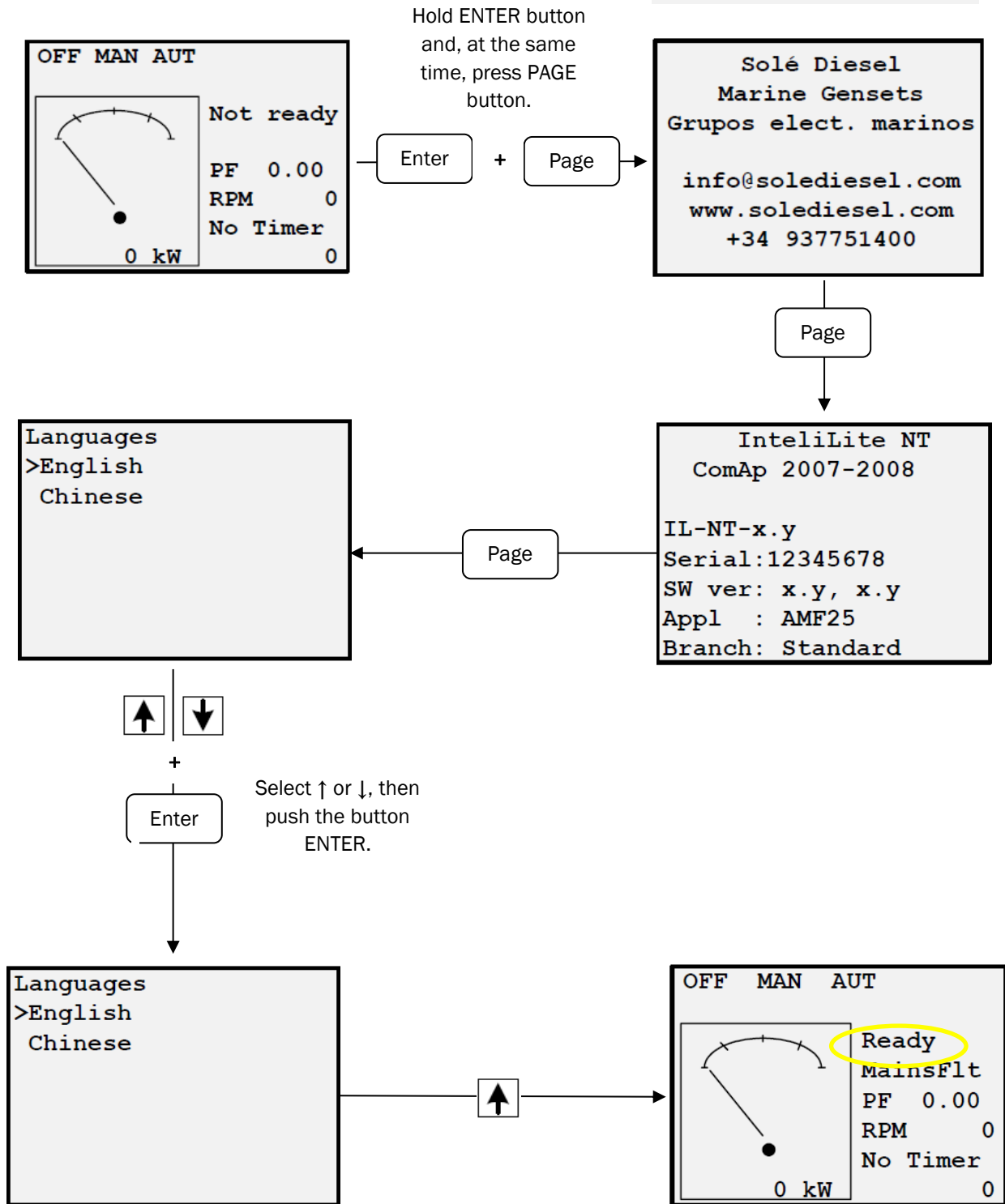

✓ The language is changed correctly.

5.3. Alarm management

The following alarms are available:

- Breaker open and cooling (BOC)
- Warning
- Shut down

5.3.1. Breaker open and cooling (BOC)

When the control panel detects a problem related to the alternator. The panel stops the genset gradually.

5.3.2. Warning (WRN)

Warning. No reason to stop the group. This is a warning to informative level. Normally it is a value of a parameter that is below / above the standard value but does not exceed the limit pre-configured to stop the engine.

5.3.3. Shut down / Apagado (SD)

When the Control Panel orders drastically stop the engine.

5.3.4. Voltage phase sequence detection

SCO 10 controller detects phase sequence on genset voltage terminals. This protection is important after controller installation to avoid wrong voltage phase connection. The following alarms can be detected:

Wrong phase sequence

There is a fix defined phase sequence in SCO 10 controller L1, L2, L3. When the phases are connected in different order (e.g. L1, L3, L2 or L2, L1, L3) the following alarms are detected:

Gen CCW Rot = wrong genset phase sequence

Hint: Phase sequence detection is active when voltage in all three phases is >50VAC and all phases angles are in the range $120^\circ \pm 20$. Phase sequence alarm detection is 1 sec delayed to avoid transient effects.

5.4. Genset operation states

5.4.1. Engine status list

Init	Autotest during controller power on
Not ready	Genset is not ready to start
Prestart	Prestart sequence in process, Prestart output is closed
Cranking	Engine is cranking
Pause	Pause between start attempts
Starting	Starting speed is reached and the <i>Idle timer</i> is running
Running	Genset is running at nominal speed
Loaded	Genset is running at nominal speed and loaded
Stop	Stop
ShutDowns	Shut-down alarm activated
Ready	Genset is ready to run
Cooling	Genset is cooling before stop
EmergMan	Emergency Manual genset operation
MinStabTO	Minimal Stabilization Timeout
MaxStabTO	Maximal Stabilization Timeout

5.4.2. Electric possible events

Events specification	Protection type	Information on binary output available	Description
Oil pressure	WRN	YES	The measured value is lower than the set point.
Oil pressure	SD	YES	The measured value is lower than the set point.
Coolant temperature	WRN	YES	The measured value is greater than the set point.
Coolant temperature	SD	YES	The measured value is greater than the set point.
Oil temperature (optional)	WRN	YES	The measured value is greater than the set point.
Oil temperature (optional)	SD	YES	The measured value is greater than the set point.
Wrn Batt Volt	WRN	YES	Battery voltage is out of limits given by <i>Batt Undervolt/Batt OverVolt</i> setpoints.
SD BatteryFlat	SD	YES	If the controller switches off during starting sequence due to bad battery condition it doesn't try to start again and activates this protection.
SD Start Fail	SD	YES	Genset start failed. All crank attempts were tried without success.
IOM ALx Wrn	WRN	YES	Warning alarm configurable on the input of IG-IOM/IGS-PTM.
IOM ALX SD	SD	YES	Shutdown alarm configurable on the input of IG-IOM/IGS-PTM.
Binary input	CONFIG.	YES	Configurable Warning/BOC/Shutdown alarms on the inputs of IL-NT.

SCO 10 panel operation



IOM Bin Inp	CONFIG.	YES	Configurable Warning/BOC/Shutdown alarms on the inputs of IL-NT.
IL-NT-BIO8	CONFIG	YES	Configurable Warning/BOC/Shutdown alarms on the inputs of IG-IOM/IGS-PTM.
ActCallCH1Fail	WRN	NO	Active call on channel 1 failed.
ActCallCH2Fail	WRN	NO	Active call on channel 2 failed.
Low BackupBatt	WRN	NO	RTC backup battery is flat
ChargeAlt Fail	WRN	YES	Failure of alternator for charging the battery.
SD Gen Lx >,<V	SD	YES	The genset voltage is out of limits given by Gen <V BOC and Gen >V Sd setpoints.
BOC Gen V Unbal	BOC	YES	The genset voltage is unbalanced more than the value of Volt Unbal BOC setpoint.
BOC Gen >, < Freq.	BOC	YES	The genset frequency is out of limits given by Gen >Freq BOC and Gen <Freq BOC setpoints.
Gen CCW Rot	WRN	NO	Genset voltage phases are not wired correctly. MCB closing is prohibited by controller.
BOC Amps Unbal	BOC	NO	The genset current is unbalanced.
BOC Amps IDMT	BOC	NO	Genset current exceeds the limit for IDMT protection given by Nominal current and Amps IDMT Del setpoints.
BOC Overload	BOC	YES	The load is greater than the value given by Overload BOC.
BOC Short Crct	BOC	YES	Genset current is higher than the value given by Short Crct BOC setpoint.
SD Earth Fault	SD	YES	This alarm is activated when Earth Fault value exceeds Earth Fault Sd limit for at least Earth Fault Del period.
SD Overspeed	SD	YES	The protection comes active if the speed is greater than Overspeed setpoint.
SD Underspeed	SD	YES	During starting of the engine when the RPM reach the value of Starting RPM setpoint the starter is switched off and the speed of the engine can drop under Starting RPM again. Then the Underspeed protection becomes active. Protection evaluation starts 5 seconds after reaching StartingRPM.
EmergencyStop	SD	NO	If the input Emergency Stop is opened shutdown is immediately activated.
SD Override	WRN	NO	The protection is active if the output Sd Override is closed.
Gcb Fail	SD	NO	Failure of genset circuit breaker.
Sd RPMMeasFail	SD	NO	Failure of magnetic pick-up sensor for speed measurement.
CheckDPFStatus	WRN	NO	ECU indicates DPF replacement.
WrnMaintenance	WRN	NO	El periodo de servicio es configurable a través del ajuste WrnMaintenance. La protección se activa si las horas de funcionamiento del motor alcanzan este valor.
Wrn FuelTheft	WRN	NO	Fuel theft indication alarm
Wrn ECU Alarm	WRN	NO	ECU alarm list is not empty
Wrn ECU Comm	WRN	YES	The controller lost communication with ECU.

SCO 10 panel operation







Sd IOM Fail	SD	NO	Shutdown alarm in case of lost connection to IG-IOM/IGS-PTM module.
Wrn RA15 Fail	WRN	NO	Warning alarm in case of lost connection to IGL-RA15 module.
ParamFail	NO	NO	Wrong checksum of parameters. Happens typically after downloading new firmware or changing of the parameter. The controller stays in INIT mode. Check all parameters, write at least one new parameter.
Wrn Exhaust Temp.	Wrn		This alarm is activated in case of an excess temperature in the exhaust gas outlet. Only if optional kit is installed.

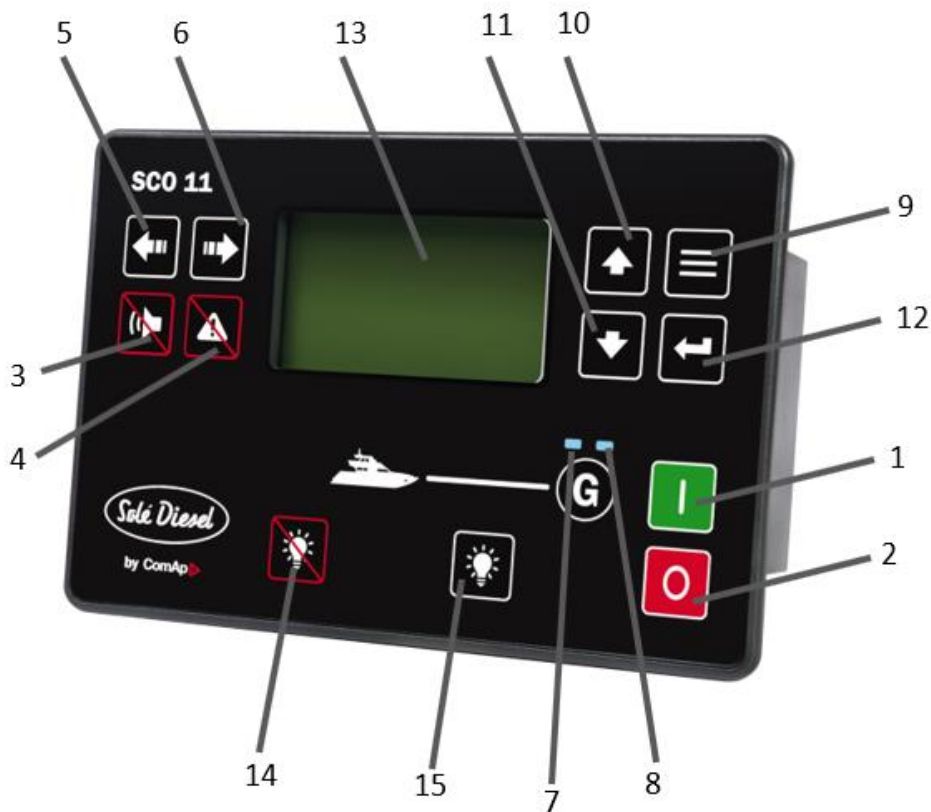

Section 6 – SCO 11 panel operation

6.1. Buttons and indicators



GENSET CONTROL BUTTONS





POSITION	BUTTON	DESCRIPTION
1		START button. Works in MAN mode only. Press this button to initiate the start sequence of the engine.
2		STOP button. Works in MAN mode only. Press this button to initiate the stop sequence of the genset. Repeated pressing or holding the button for more than 2s will cancel current phase of stop sequence (like ramping the power down or cooling) and next phase will continue.
3		HORN RESET button. Use this button to deactivate the horn output without acknowledging the alarms.
4		FAULT RESET button. Use this button to acknowledge alarms and deactivate the horn output. Inactive alarms will disappear immediately and status of active alarms will be changed to "confirmed" so they will disappear as soon as their reasons dismiss.

POSITION	BUTTON	DESCRIPTION
5		MODE LEFT button. Use this button to change the mode. The button works only if the main screen with the indicator of currently selected mode is displayed. Note: This button will not work if the controller mode is forced by one of the binary inputs Remote OFF, Remote MAN, Remote AUT.
6		MODE RIGHT button. Use this button to change the mode. The button works only if the main screen with the indicator of currently selected mode is displayed. Note: inputs Remote OFF, Remote MAN, Remote AUT.

GENSET OPERATION INDICATORS

POSITION	BUTTON	DESCRIPTION
7		Genset voltage OK. Green LED is on if the genset voltage is present and within limits.
8		Genset failure. Red LED starts flashing when genset failure occurs. After FAULT RESET button is pressed, the light steadies (if an alarm is still active) or turns off (if no alarm is active).

BOTONES DE VISUALIZACIÓN Y CONTROL

POSITION	BUTTON	DESCRIPTION
9		PAGE button. Use this button to switch between display pages. See Section 6.2. <i>Display screens and page's structure</i> below this table for more details.
10		UP button. Use this button to go up or increase a value.
11		DOWN button. Use this button to go down or decrease a value.
12		ENTER button. Use this button to finish editing a setpoint or moving right in the history page.
13		Graphic B/W display, 132x64 pixels.
14		Modo oscuro

15		Light mode
----	---	------------

6.2. Display screens and page's structure

The displayed information is structured into "pages" and "screens". Use PAGE button to switch over the pages.

4. The *Measurement* page consists of screens which display measured values like voltages, current, oil pressure etc., computed values like genset power, statistic data and the alarm list on the last screen.
5. The *Setpoints* page contains all setpoints organized in groups and also a special group for entering password.
6. The *History log* page shows the history log in reverse order, so the last record is displayed first.

6.2.1. Measurement

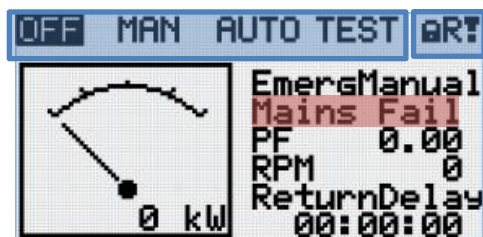

- Symbols
 - Padlock: panel locked.
 - R: remote control connected.
 - Exclamation: there is an alarm in the alarm list.
- Mode selector
- Generator status
- Power factor*
- RPM
- Timer in seconds for each phase of the genset
- Active Power Indicator Needle*
- **Mains Fail**: Unused message

Operating modes

- **OFF**: The engine cannot be started. This mode is used as a safety measure.
- **MAN**: Manual mode. Normal operating mode.
- **AUT**: Automatic mode. Mode for remote starting.
- **TEST**: Operation mode not available.



Generator			
L1N	230V	L1L2	400V
L2N	230V	L2L3	400V
L3N	230V	L3L1	400V
Generator Freq		50.0Hz	

- Voltage between phases and neutral
- Voltage between different phases
- Genset frequency



Generator Current	
L1	130A
L2	130A
L3	130A

- Electric current / Phase current*



*Para poder visualizar estos valores es necesario tener instalado el Pack Amperométrico.

Analog Inputs 1/2	
Oil Pressure	#####Bar
Coolant Temp	##### °C
Not Used	

- Oil pressure
- Engine coolant temperature
- Not used



Analog Inputs 2/2	
BatteryVoltage	23.8V

- Battery voltage

Binary inputs – Binary signals from the genset to control panel.



Binary Inputs 1/2		
0000000		
1	High Coolant Temp.	0
2	Exhaust Temperature	0
3	Low Oil Press.	0
4	Remote Start/Stop	0
5	Sd Override	0

- BI1: Alarm / Temperature switch.
- BI2: Exhaust gas temperatura*.
- BI3: Alarm / Pressure switch.
- BI4: Remote control – Start / Stop.
- BI5: Sd Override.

Binary Inputs 2/2		
000000		
6	Delta Configuration	0
E-STOP		1

- BI6: Delta Configuration.
- E-Stop.

Binary outputs – Binary outputs from the control panel to the genset.



Binary Outputs 1/2		
00000000		
1	Starter	0
2	Fuel Solenoid	0
3	Fuel Pump	0
4	Preheating	0
5	Not used	0

- BO1: Cranking signal.
- BO2: Stop Solenoid.
- BO3: Feed pump.
- BO4: Preheating.
- BO5: Not used.
-



Binary Outputs 2/2		
000000		
6	Not used	0

- BO6: Not used.



Generator Power			
	kW	PF	kVA
L1	0	0.00C	0
L2	0	0.00C	0
L3	0	0.00C	0
Σ	0	0.00C	0

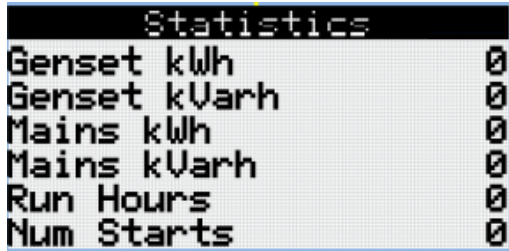

- The left column shows the active power of each phase and total current (if the amperometric kit is installed).
- The middle column shows the power factor of each phase and total (if the amperometric kit is installed).
- The right column shows the apparent power of each phase and total.



If you do not understand the description of the alarm, it is recommended to change the language to English.

If you still have doubts, please contact the factory.

6.2.2. Setpoint. Controller information screen

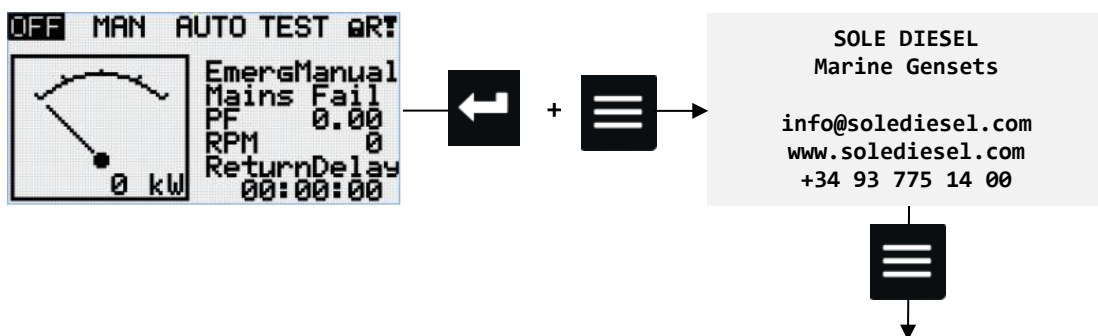

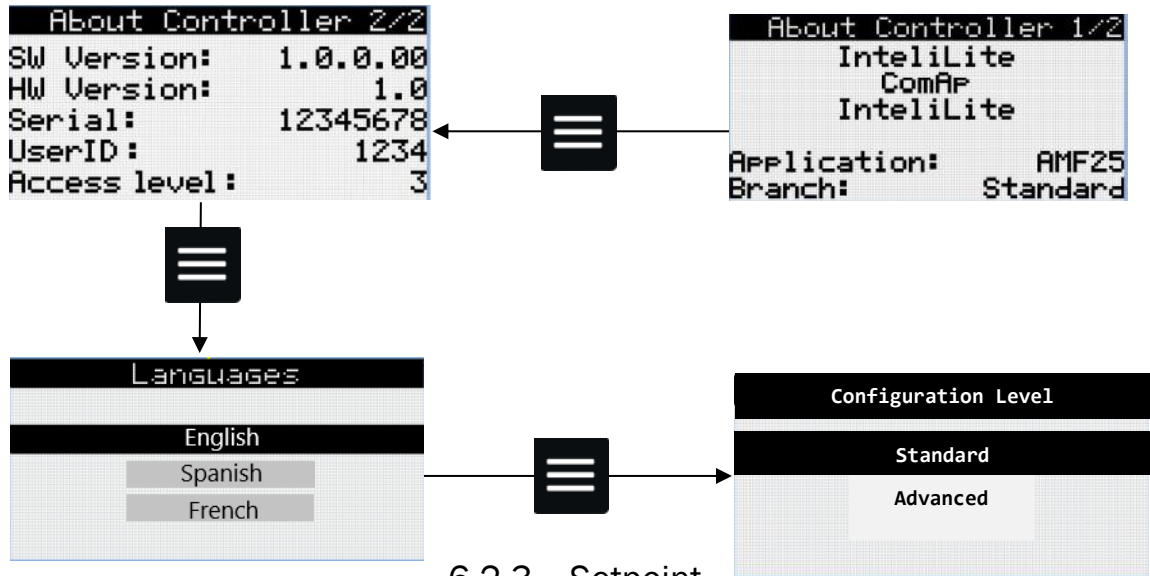

6.2.3. Setpoint.

Maintenance hours change

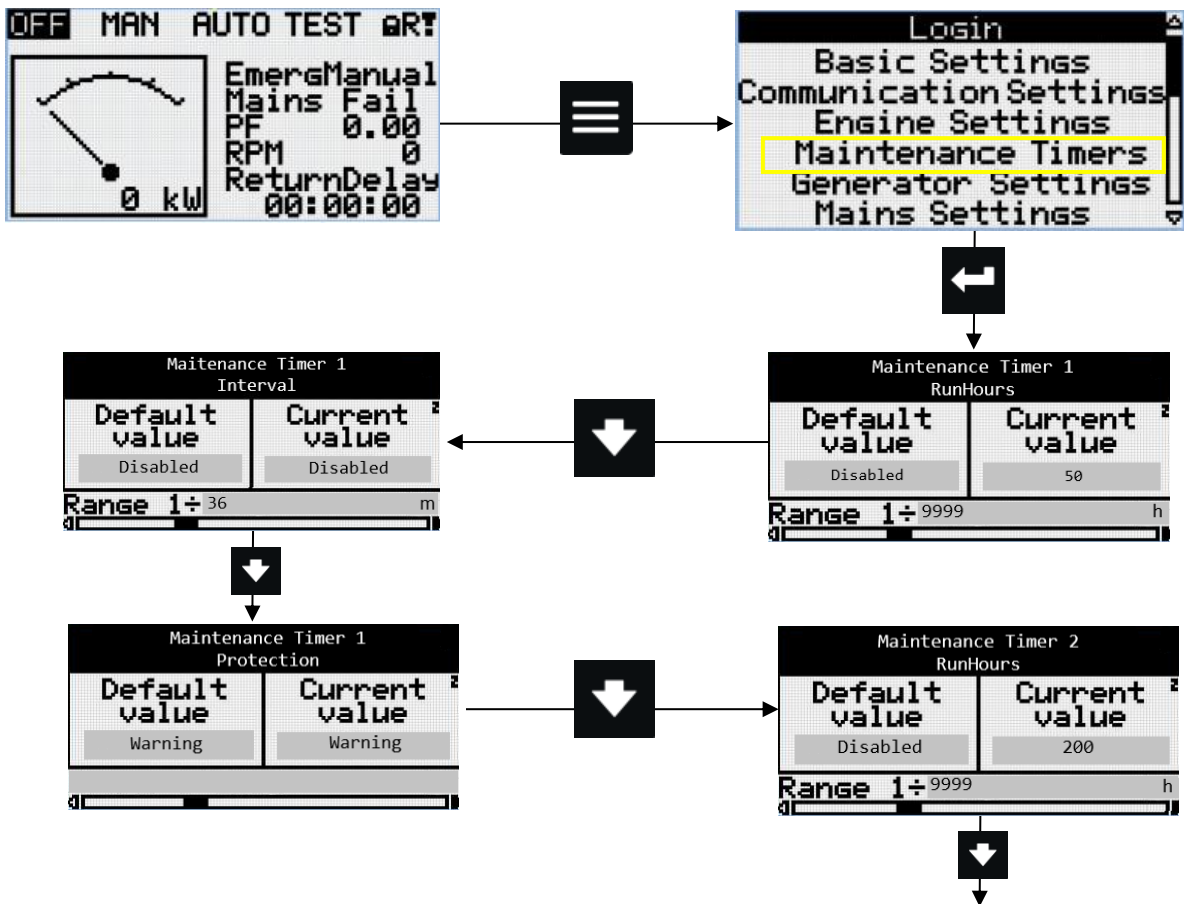

SCO 11 panel operation

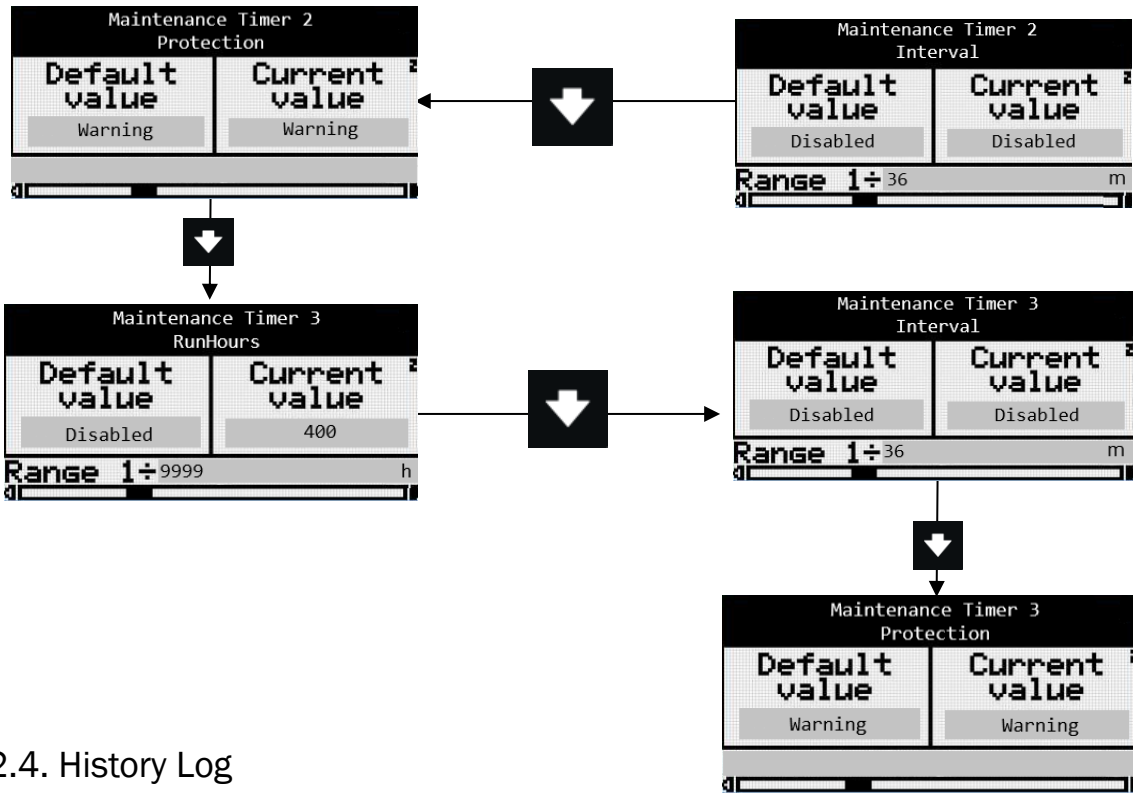

6.2.4. History Log

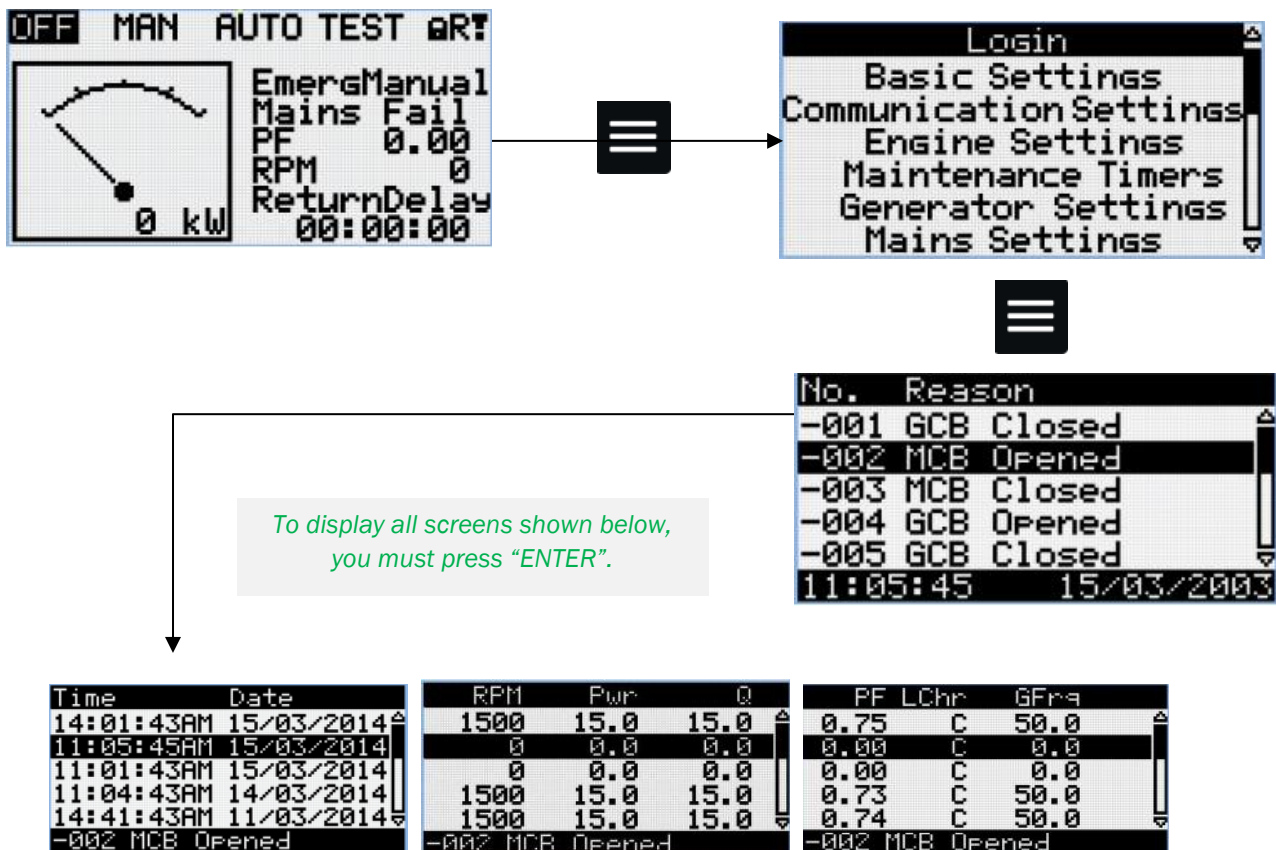

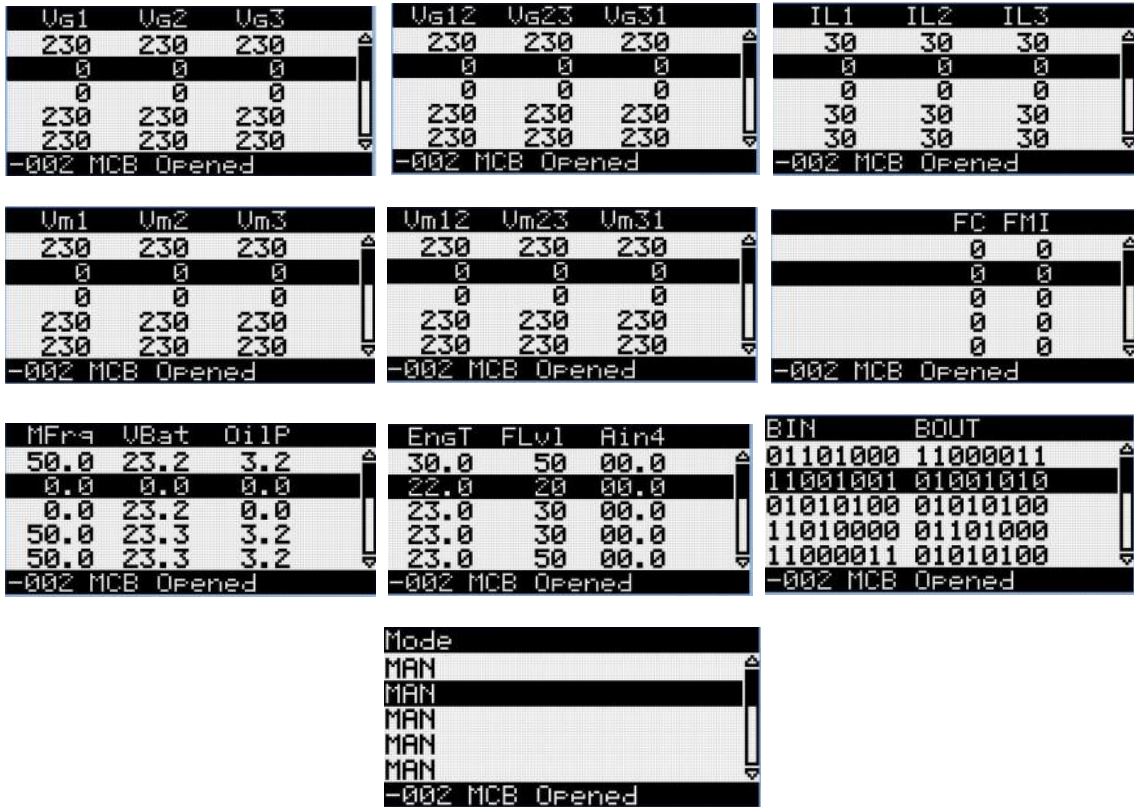

6.2.5. Alarms list

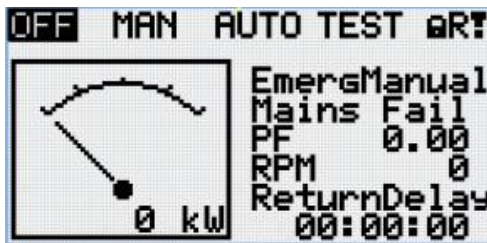

- Number of alarms
- Active unconfirmed alarm
- Inactive unconfirmed alarm
- Active confirmed alarm
- ECU Alarms

6.2.6. Display contrast adjustment

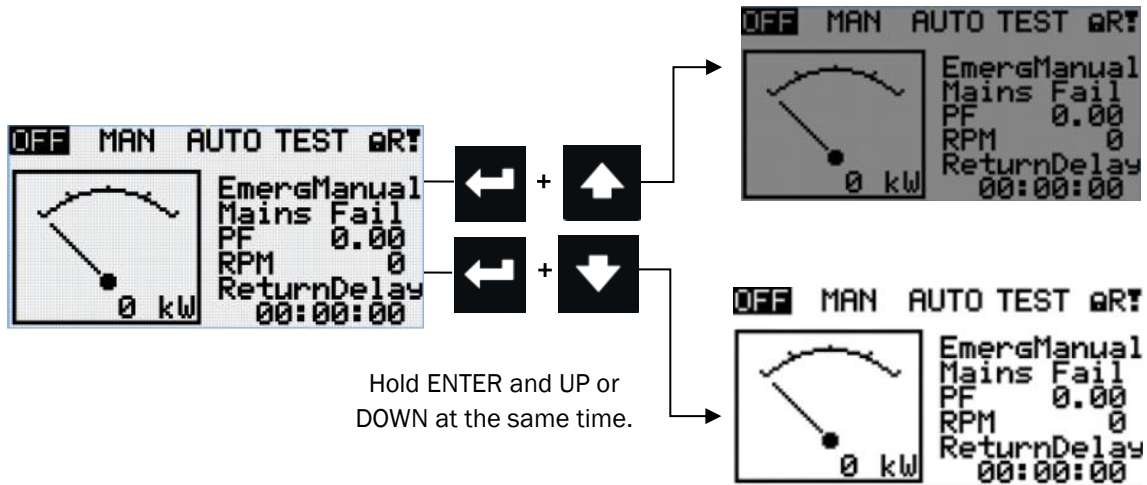

If the panel is more than 5 seconds in a screen, it returns to initial screen automatically. In this case, you must begin all the procedure again.

6.2.7. Change language

You must follow these steps to change the panel language.

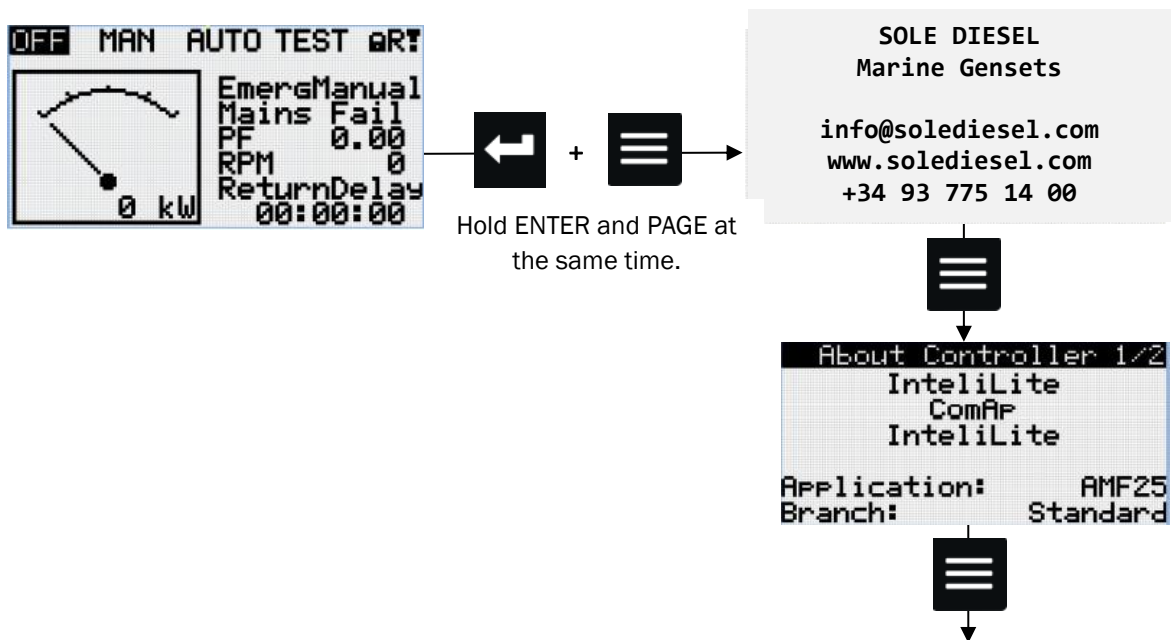

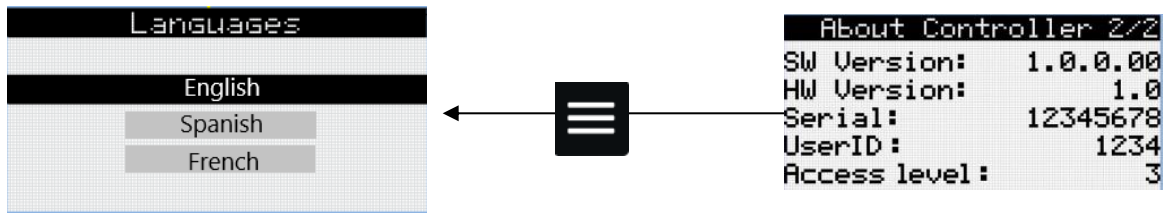

Select with the UP or DOWN button and confirm with ENTER button.

6.3. Alarm management

The following alarms are available:

- Breaker open and cooling (BOC)
- Warning (WRN)
- Shut down (SD)
- Sensor Fail (FLS)

6.3.1. Breaker open and cooling (BOC)

When the control panel detects a problem related to the alternator. The panel stops the genset gradually.

6.3.2. Warning (WRN)

Warning. No reason to stop the genset. This is a warning that gives information. Normally it is a value of a parameter that is below / above the standard value but does not exceed the limit pre-configured to stop the engine.

6.3.3. Shut down / Apagado (SD)

This type of alarm indicates that a critical level of the respective value or parameter has been reached. In this case, the Control Panel orders the engine to stop drastically.

6.3.4. Sensor Fail (FLS)

If the resistance measured at one of the analogue inputs exceeds the valid range, a sensor failure will be detected, and a sensor failure message will appear in the alarm list. This alarm does not stop the genset.

6.3.5. Voltage phase sequence detection

SCO 10 controller detects phase sequence on genset voltage terminals. This protection is important after controller installation to avoid wrong voltage phase connection. The following alarms can be detected:

Wrong phase sequence

There is a fix defined phase sequence in SCO 11 controller L1, L2, L3. When the phases are connected in different order (e.g. L1, L3, L2 or L2, L1, L3) the following alarms are detected:

ALI Gen Ph Rotation Opposite = wrong genset phase sequence.

Hint: Phase sequence detection is active when voltage in all three phases is >50VAC and all phases' angles are in the range $120^\circ \pm 20$. Phase sequence alarm detection is 1 sec delayed avoiding transient effects.

6.4. Genset operation states

6.4.1. Engine status list

Ready	Autotest during controller power on
Not ready	Genset is not ready to start
Prestart	Prestart sequence in process, Prestart output is closed
Cranking	Engine is cranking
Crank Pause	Pause between start attempts
Starting	Starting speed is reached and the <i>Idle timer</i> is running
Running	Genset is running at nominal speed
Loaded	Genset is running at nominal speed and loaded
Stop	Stop
Shutdown	Shut-down alarm activated
Cooling	Genset is cooling before stop
EmergMan	Emergency Manual genset operation

6.4.2. Electric possible events

Events specification	Protection type	Information on binary output available	Description
Oil pressure	WRN	YES	The measured value is lower than the set point.
Oil pressure	SD	YES	The measured value is lower than the set point.
Coolant temperature	WRN	YES	The measured value is greater than the set point.
Coolant temperature	SD	YES	The measured value is greater than the set point.
Oil temperature (optional)	WRN	YES	The measured value is greater than the set point.
Oil temperature (optional)	SD	YES	The measured value is greater than the set point.
Wrn Battery Overvoltage/Undervoltage	WRN	YES	Battery voltage is out of limits given by <i>Batt Undervolt/Batt OverVolt</i> setpoints.
SD BatteryFlat	SD	YES	If the controller switches off during starting sequence due to bad battery condition it doesn't try to start again and activates this protection.
Wrn Stop Fail	WRN	NO	This alarm occurs if the generating set should be stopped, but some symptom indicates that it is not stopped.
Wrn Maintenance	WRN	NO	The service period is configurable via the <i>WrnMaintenance</i> setting. The protection is activated if the engine operating hours reach this value.

SCO 11 panel operation



SD Start Fail	SD	YES	Failed genset start.
Wrn Charging Alternator Fail	WRN	YES	Failure of alternator for charging the battery.
Wrn Battery <>Voltage	WRN	YES	This alarm informs the operator that the supply voltage to the controller is too high or too low.
WRN Generator Lx Overvoltage/Undervoltage SD Gen Lx Overvoltage BOC Gen Lx Undervoltage	WRN SD BOC	YES	The generator voltage is outside the limits given by the Generator Undervoltage BOC and Generator Overvoltage Sd setpoints.
BOC Gen V Unbal	BOC	YES	The genset voltage is unbalanced more than the value of <i>Volt Unbal BOC</i> setpoint.
BOC Generator Overfrequency/Underfrequency	BOC	YES	The genset frequency is out of limits given by <i>Gen >Freq BOC</i> and <i>Gen <Freq BOC</i> setpoints.
ALI Gen Ph Rotation Opposite	WRN	NO	The generator voltage phases are not connected correctly.
BOC Current Unbalance	BOC	NO	Generator current is unbalanced.
Wrn Exhaust Temp.	WRN		This alarm is activated in case of an excess temperature in the exhaust gas outlet. <i>Only if Exhaust Temperature Alarm optional kit is installed.</i>
BOC Overload	BOC	YES	The load is greater than the value given by the Overload setpoint.
BOC Short Circuit	BOC	YES	The generator current is greater than the value given by the Short Circuit BOC setting.
SD Earth Fault	SD	YES	This alarm is activated when Earth Fault value exceeds <i>Earth Fault Sd</i> limit for at least <i>Earth Fault Del</i> period.
SD Overspeed	SD	YES	The protection comes active if the speed is greater than <i>Overspeed</i> setpoint.
SD Underspeed	SD	YES	During starting of the engine when the RPM reach the value of <i>Starting RPM</i> setpoint the starter is switched off and the speed of the engine can drop under <i>Starting RPM</i> again. Then the Underspeed protection becomes active. Protection evaluation starts 5 seconds after reaching <i>StartingRPM</i> .
Emergency Stop	SD	NO	If the input <i>Emergency Stop</i> is opened shutdown is immediately activated.
SD Override	WRN	NO	The protection is active if the output <i>Sd Override</i> is closed.
GCB Fail	SD	NO	Failure of genset circuit breaker.
Sd RPM Measurement Fail	SD	NO	Failure of the magnetic speed measurement sensor.
Wrn Fuel Transfer Failed	WRN	NO	This alarm occurs when there is no fuel level rise when the fuel pump is active.
Sd ECU Communication Fail	SD	YES	The controller has lost connection with the ECU.
Wrn ECU Communication Fail	WRN	YES	The controller has lost connection with the ECU.
Sd EM(A)	SD	NO	Shutdown alarm in case of loss of connection to the module.
Wrn EM(A)	WRN	NO	Warning alarm in case of loss of connection to the module.

6.5. Connections description

	Code	Terminal	Tipo de señal	Description	Color
Engine Monitoring	AI1	T23	Analog Input	Oil pressure sensor	Brown
	AI2	T24	Analog Input	Coolant temperatura sensor	Grey
	AI3	T25	Analog Input	-	-
	COM	T20	-	COM	Black
	BI1	T60	Binary Input	Coolant temperatura switch	White
	BI2	T61	Binary Input	Exhaust temperatura switch	Orange
	BI3	T62	Binary Input	Oil pressure switch	Blue
	BI4	T63	Binary Input	Remote Control - Start/Stop	-
	BI5	T64	Binary Input	Sd Override	-
	BI6	T65	Binary Input	Delta Configuration	-
	ESTOP	T09	Binary Input	E-Stop	Red
	B01	T10	Binary Output	Starter signal	Pink
	B02	T11	Binary Output	Stop solenoid	Yellow
	B03	T12	Binary Output	Fuel feed pump	Green
	B04	T13	Binary Output	Glow plugs	Green-White
	B05	T14	Binary Output	-	-
B06	T15	Binary Output	-	-	
Genset Monitoring	-	T44	Analog Input	N phase voltage	Blue-White
	-	T46	Analog Input	L1 phase voltage	Black-White
	-	T48	Analog Input	L2 phase voltage	Brown-White
	-	T50	Analog Input	L3 phase voltage	Grey-White
	-	T39	Analog Input	COM*	Blue
	-	T40	Analog Input	L1 phase current*	Black
	-	T41	Analog Input	L2 phase current*	Brown
	-	T42	Analog Input	L3 phase current*	Grey

Section 7 – Sensors and switches specifications

Coolant temperature sensor:

- Operating voltage: 6-24V
- Operating current: <85mA, Pmax<0.25W
- Operating temperature: -40°C to +120°C
- Measuring range: -40°C to +120°C
- Absolute max. value: 130°C, max. 1 min.
- Protection: BODY IP 67
- Tightening torque: Max. 20Nm

Function table

Temperature (°C)	Resistance (ohm)	Tolerance (ohm)
40	287.4	±32.8
60*	134	±13.5
80	69.1	±6.5
90*	51.2	±4.3
100*	38.5	±3.0
120	22.7	±2.2

*Test point

Oil pressure sensor:

- Operating voltage: 6-24V
- Operating current: >20mA, <85mA, Pmax<0.25W
- Operating temperature: -20°C to +100°C
- Measuring range: 0 – 10 BAR
- Absolute max. value: 30 BAR, max. 2 seconds.
- Protection: BODY IP 67
- Tightening torque: Max. 20Nm

Function table

Pressure (BAR)	Resistance (ohm)	Tolerance (ohm)
0	10	+3/-5
2	52	±4
4	88	±4
6	124	±5
8	155	±5
10	184	+20/-10

Coolant temperature sensor specifications (two pole)

- Operating voltage: 6-24V
- Operating current: <85mA, Pmax<0.25W
- Operating temperature: -40°C to +120°C
- Measuring range: -40°C to +120°C
- Absolute max. value: 130°C, max. 1 min.
- Protection: BODY IP 67
- Tightening torque: Max. 20Nm

Function table

Temperature (°C)	Resistance (ohm)	Tolerance (ohm)
40	287.4	±32.8
60*	134	±13.5
80	69.1	±6.5
90*	51.2	±4.3
100*	38.5	±3.0
120	22.7	±2.2

*Test point

Sensors and switches specifications



Oil pressure sensor (two pole):

- Operating voltage: 6-24V
- Operating current: >20mA, <85mA, Pmax<0.25W
- Operating temperature: -20°C to +100°C
- Measuring range: 0 – 10 BAR
- Absolute max. value: 30 BAR, max. 2 seconds.
- Protection: BODY IP 67
- Tightening torque: Max. 20Nm

Function table

Pressure (BAR)	Resistance (ohm)	Tolerance (ohm)
0	10	+3/-5
2	52	±4
4	88	±4
6	124	±5
8	155	±5
10	184	+20/-10

TEMPERATURE SWITCH:

- Operating voltage: 12-24V
- Operating power: 5W
- Operating temperature: ≤100°C ±4°C (OPEN CIRCUIT), ≥100°C±2°C (CLOSE CIRCUIT)

OIL PRESSURE SWITCH:

- Operating voltage: 12V
- Operating power: 5W
- Operating pressure: 0.98bar (CLOSE CIRCUIT)

TEMPERATURE SWITCH (TWO POLE)

- Operating voltage: 6-24V
- Operating power: Max 100W
- Operating temperature: 96°C ±3°C (CLOSE CIRCUIT)

OIL PRESSURE SWITCH (TWO POLE):

- Operating voltage: 6-24V
- Operating current: <0.5A
- Operating pressure: 0.4bar±0.15bar (CLOSE CIRCUIT)

Section 8 – Optional equipment

8.1. Panel SCO 5 / Panel SCO 10 / SCO 11 Amperometric Pack

In order to measure the phase current, it is necessary to install the Amperometric Pack, supplied as an option. The necessary toroidal transformers are included in each pack and must be suitable for each genset set model. For this, the CT ratio corresponding to each model must be considered.

8.2. SCO 10 Second Panel Kit

The second panel kit consists of a remote SCO 10 panel, two communication cards (one for each panel) and communication wire.

To install the remote panel, first connect the communication wire between the main SCO 10 panel and the remote SCO 10 panel as shown below. Please note that the black colored wire of the communication wire at the end of the remote SCO 10 must be grounded.



MAIN SCO 10 communication wire end



REMOTE SCO 10 communication wire end

Finally, it is necessary to connect the remote SCO 10 Panel to an 8 to 36 V power supply (red wire to the positive and black wire to the negative of the source).

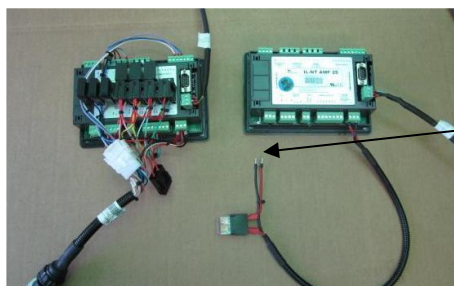

Connect to a power source (8 to 36 V).

The communication wire is supplied with the following lengths: 12 meters, 24 meters, 36 meters and 60 meters.

▲ NOTICE

The second panel kit is only available in the SCO 10 model. It is not possible to operate the SCO 5 panel remotely through another SCO panel.

8.3. SCO 10 Third Panel Kit

The third panel kit consists of two remote SCO 10 panel, three communication cards (one for each panel) and a communication wire.

To install the remotes panels, first connect the communication wires between the main SCO 10 panel and the remotes SCO 10 panel as shown below. Please note that the black colored wire of the communication wire at the end of the remote SCO 10 must be grounded.



MAIN SCO 10 communication wire end



REMOTE SCO 10 communication wire end (1)

The communication wire is supplied with the following lengths: 12 meters, 24 meters, 36 meters and 60 meters.

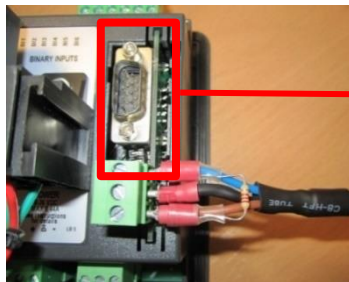

MAIN SCO 10 communication wire end



REMOTE SCO 10 communication wire end (2)

The communication cable for the second remote panel is not supplied with this kit and the maximum length may be 10 metres.

Finally, it is necessary to connect the remote SCO 10 Panel to an 8 to 36 V power supply (red wire to the positive and black wire to the negative of the source).

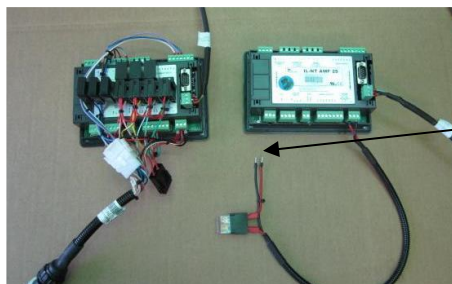

Connect to a power source (8 to 36 V).

NOTICE

The second panel kit is only available in the SCO 10 model. It is not possible to operate the SCO 5 panel remotely through another SCO panel.

8.4. SCO 11 Second Panel Kit

The second panel kit consists of a remote SCO 11 panel, two communication cards (one for each panel) and a communication cable available in various lengths depending on the user's needs.

To install the remote panel, first the communication cable must be connected between the main SCO 11 panel and the remote SCO 11 panel as shown below. It should be noted that the black-coloured wire of the communication cable at the remote SCO 11 end must be connected to ground.



MAIN SCO 11 communication wire

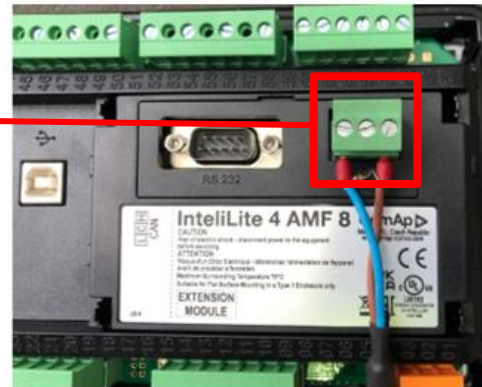

REMOTE SCO 10 communication wire

Finally, it is necessary to connect the remote SCO 10 Panel to an 8 to 36 V power supply (red wire to the positive and black wire to the negative of the source).

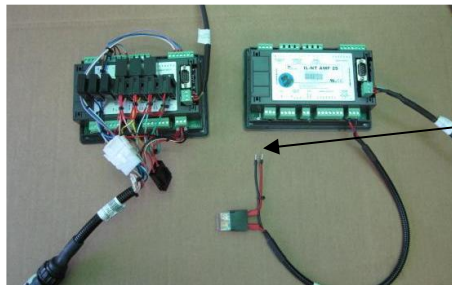

Connect to a power source (8 to 36 V).

The communication wire is supplied with the following lengths: 12 meters, 24 meters, 36 meters and 60 meters.

NOTICE

The second panel kit is only available in the SCO 11 model. It is not possible to operate the SCO 5 panel remotely through another SCO panel.

8.5. SCO 11 Third Panel Kit

The triple panel kit consists of two remote SCO 11 panels and three communication cards (one for each panel) and a communication wire.

To install the remote panels, first of all connect the communication cable between the main SCO 11 panel and the remote SCO 11 panel as shown below. It should be noted that the black coloured wire of the communication cable at the remote SCO 10 end must be connected to ground.

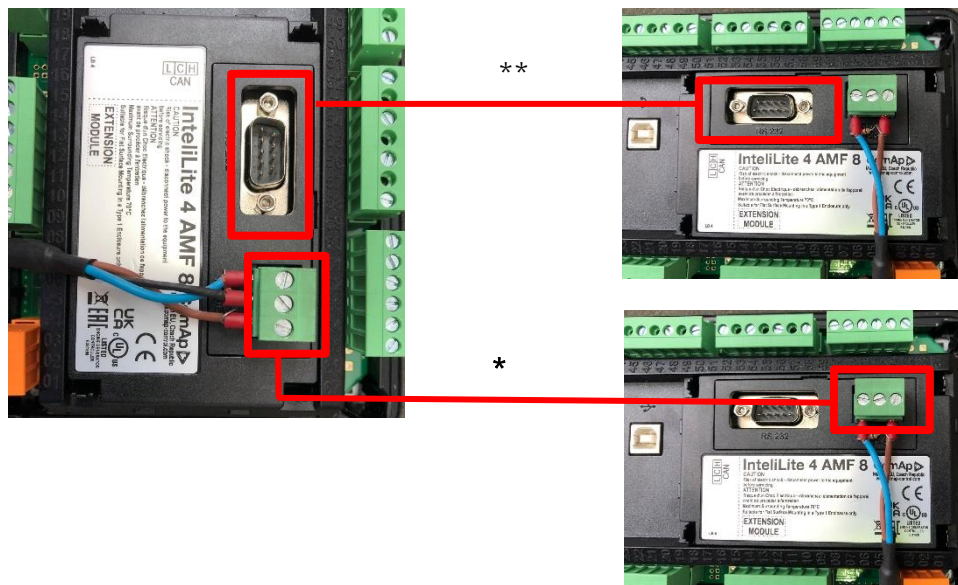

*The communication wire is supplied with the following lengths: 12 meters, 24 meters, 36 meters and 60 meters.

**The communication cable for the second remote panel is not supplied with this kit and the maximum length may be 10 meters.

Finally, it is necessary to connect the remote SCO 10 Panel to an 8 to 36 V power supply (red wire to the positive and black wire to the negative of the source).

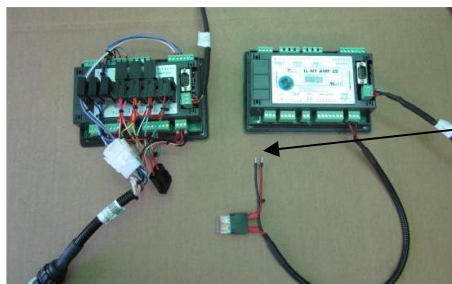

Connect to a power source (8 to 36 V).

▲ NOTICE

The third panel kit is only available in the SCO 11 model. It is not possible to operate the SCO 5 panel remotely through another SCO panel.



Section 9 – Electrical wiring diagrams

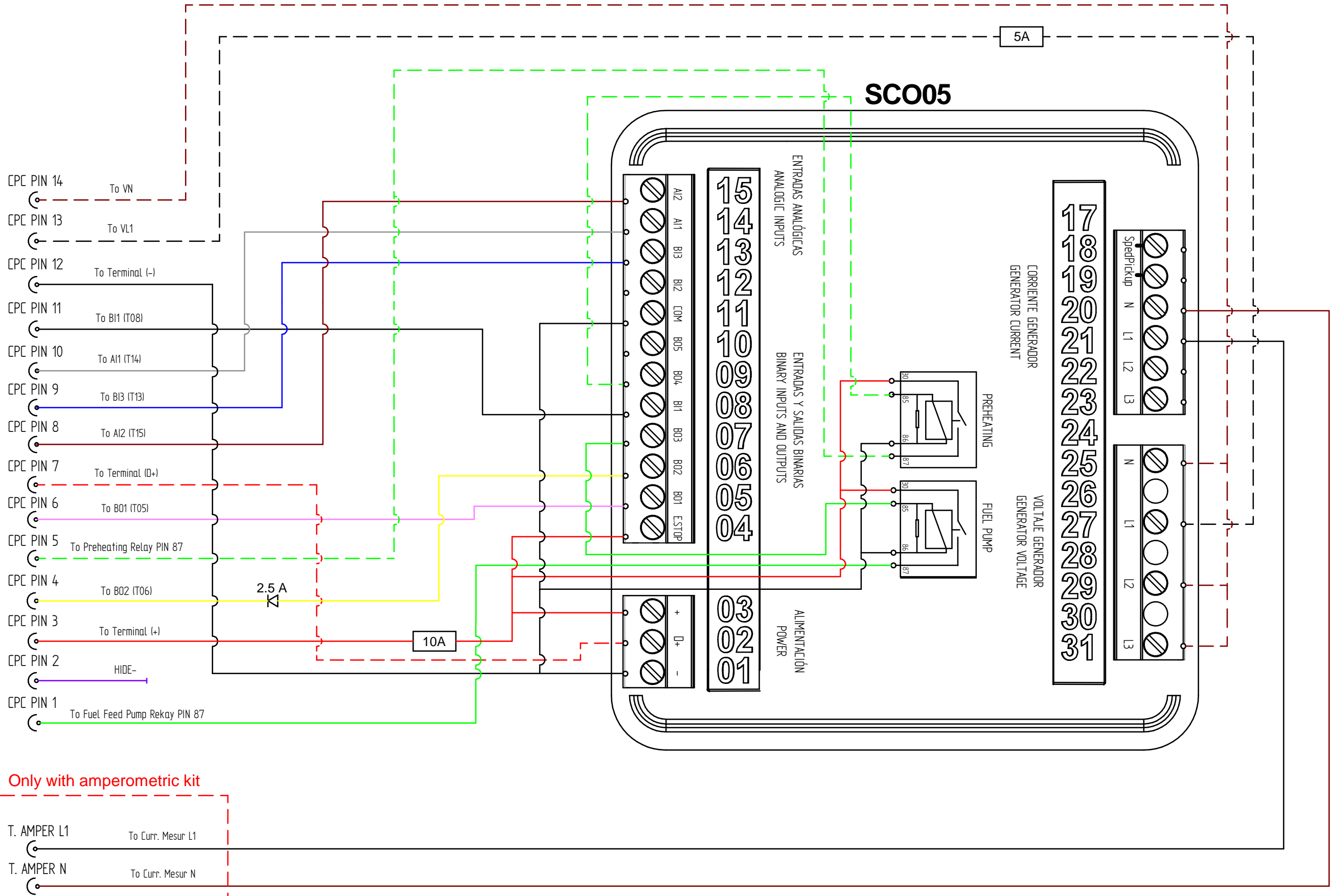

Only with amperometric kit

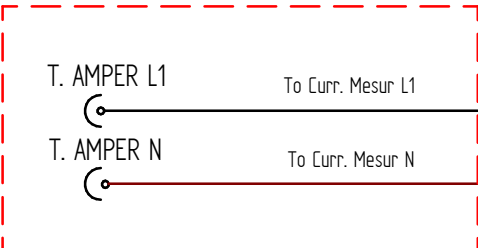

INSTALACIÓN POSTERIOR SCO 05 (1PH)				
DIBUJADO MARC G.	VERIFICADO RUBEN D.	FECHA CREACIÓN 28/02/2020	ÚLTIMA REVISIÓN	PÁGINA
SOLÉ, S.A.		60972123M		1 de 4

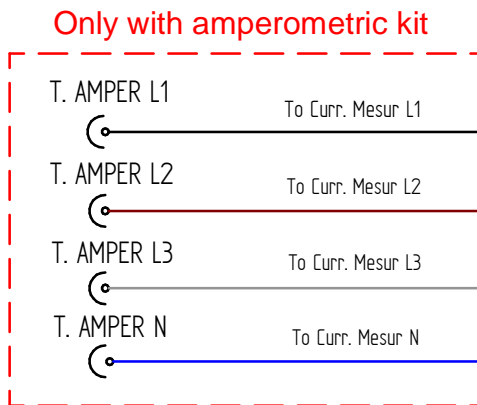
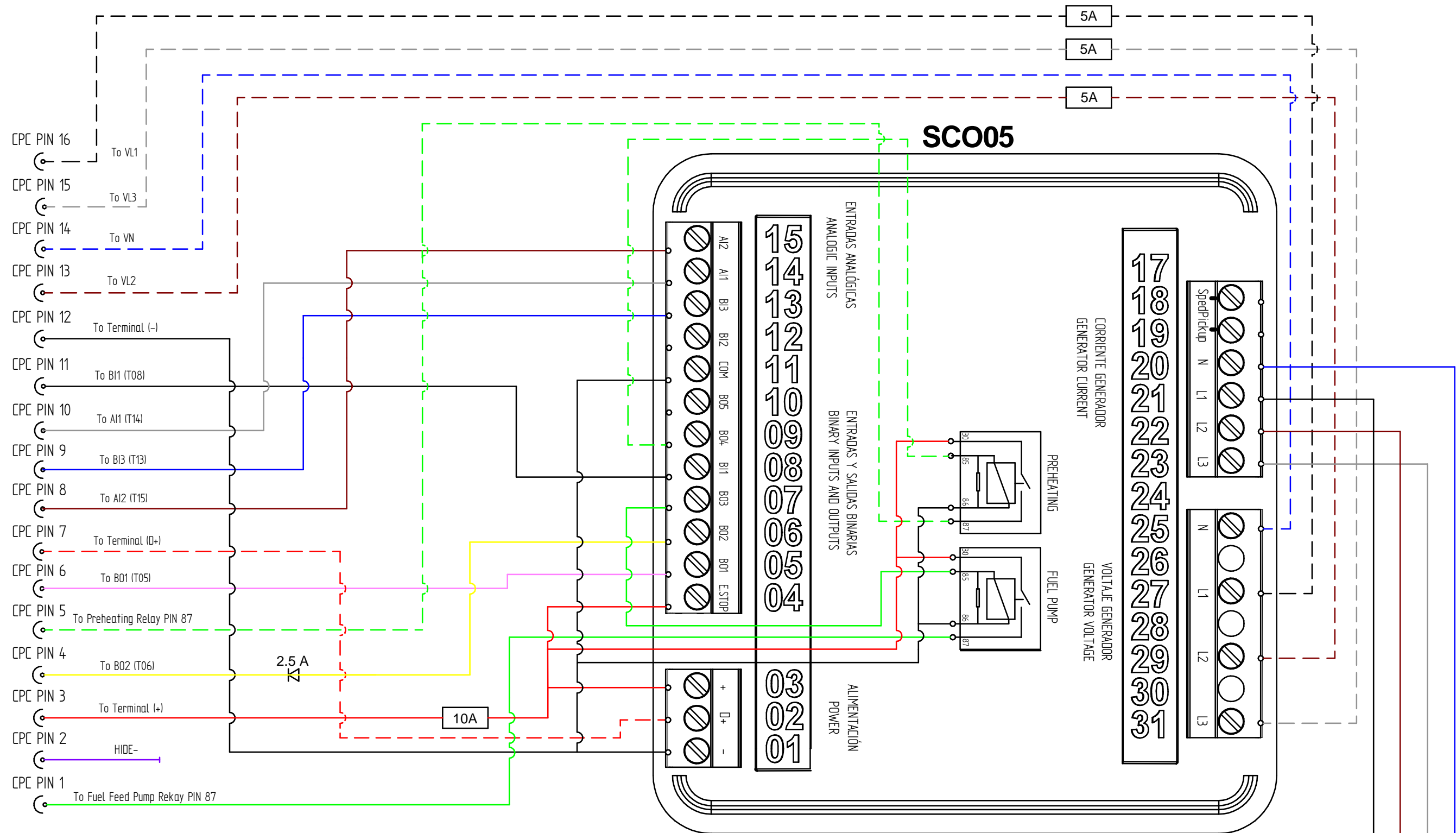

INSTALACIÓN POSTERIOR SCO 05 (3PH)				
DIBUJADO MARC G.	VERIFICADO RUBEN D.	FECHA CREACIÓN 28/02/2020	ÚLTIMA REVISIÓN	PÁGINA
SOLÉ, S.A.		60972123T		2 de 4

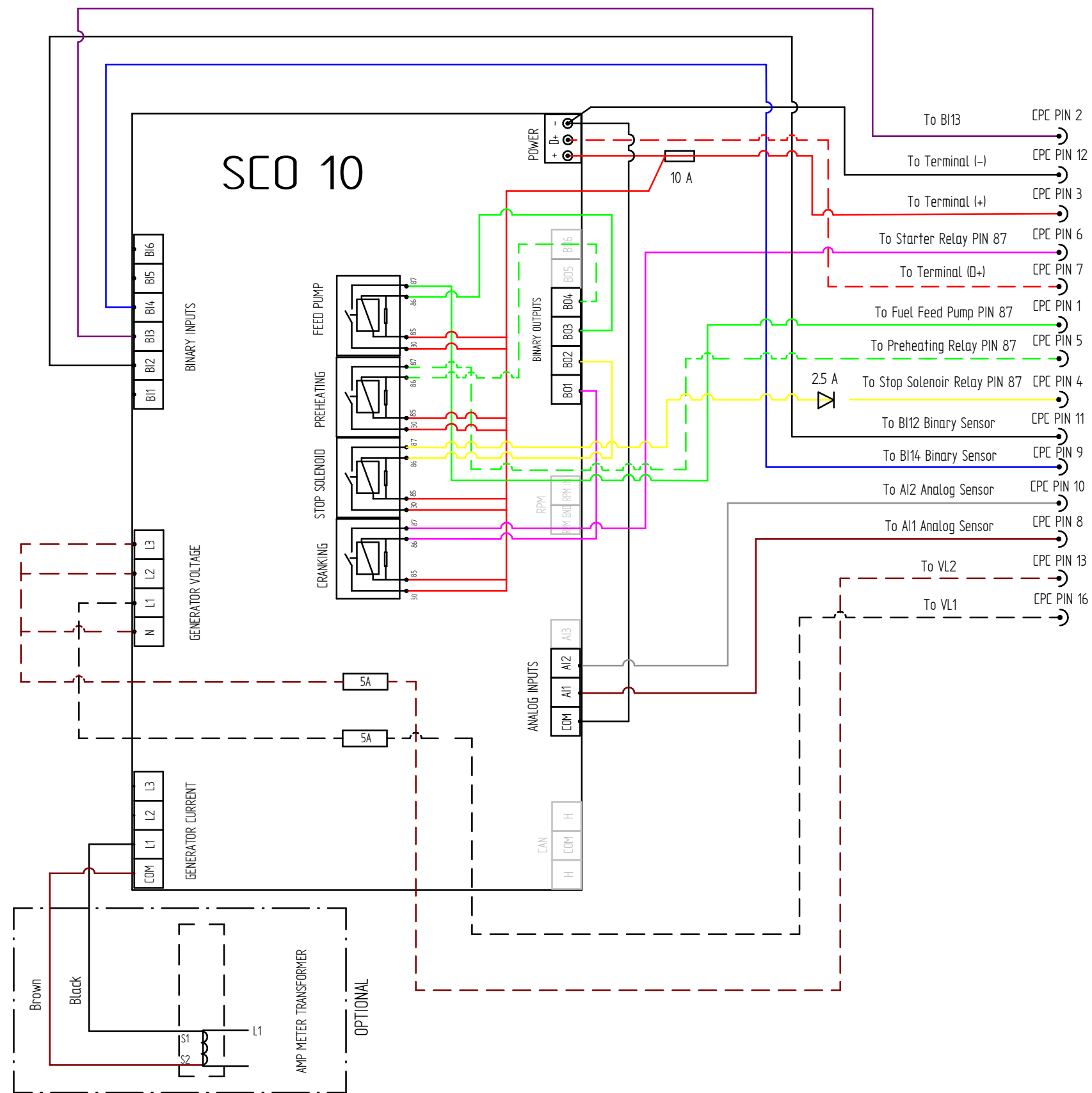

CPC 16 PIN

1 Phase Connection SCO 10				
DRAWN DANIEL R.	VERIFIED RUBEN D.	CREATION DATE 28/01/2019	LAST REVISION 16/02/2021	PAGE
 SOLE, S.A.				1

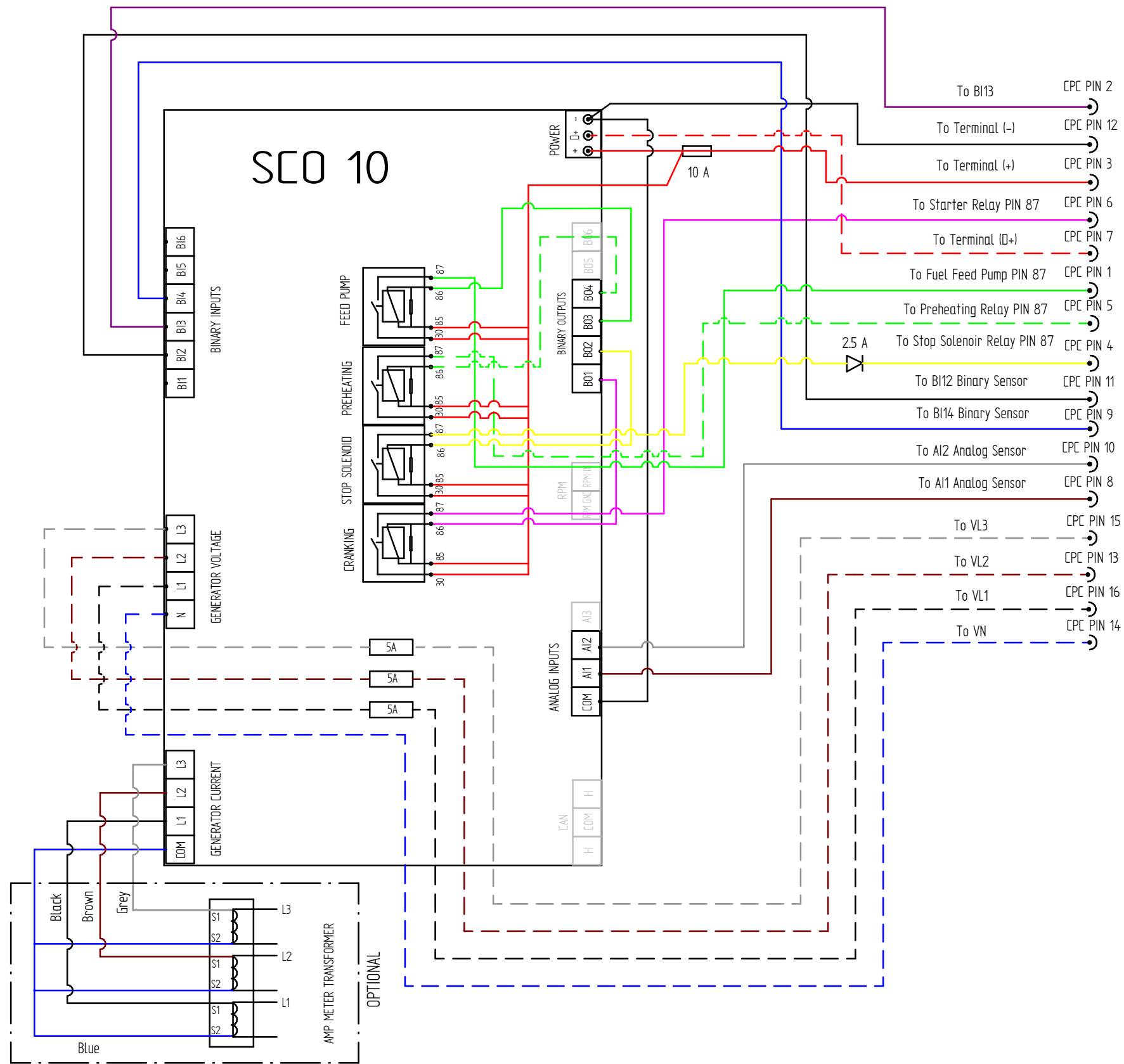

3 Phase Connection SCO 10

DRAWN	VERIFIED	CREATION DATE	LAST REVISION	PAGE
DANIEL R.	RUBEN D.	28/01/2019	16/02/2021	1
 SOLE, S.A.				

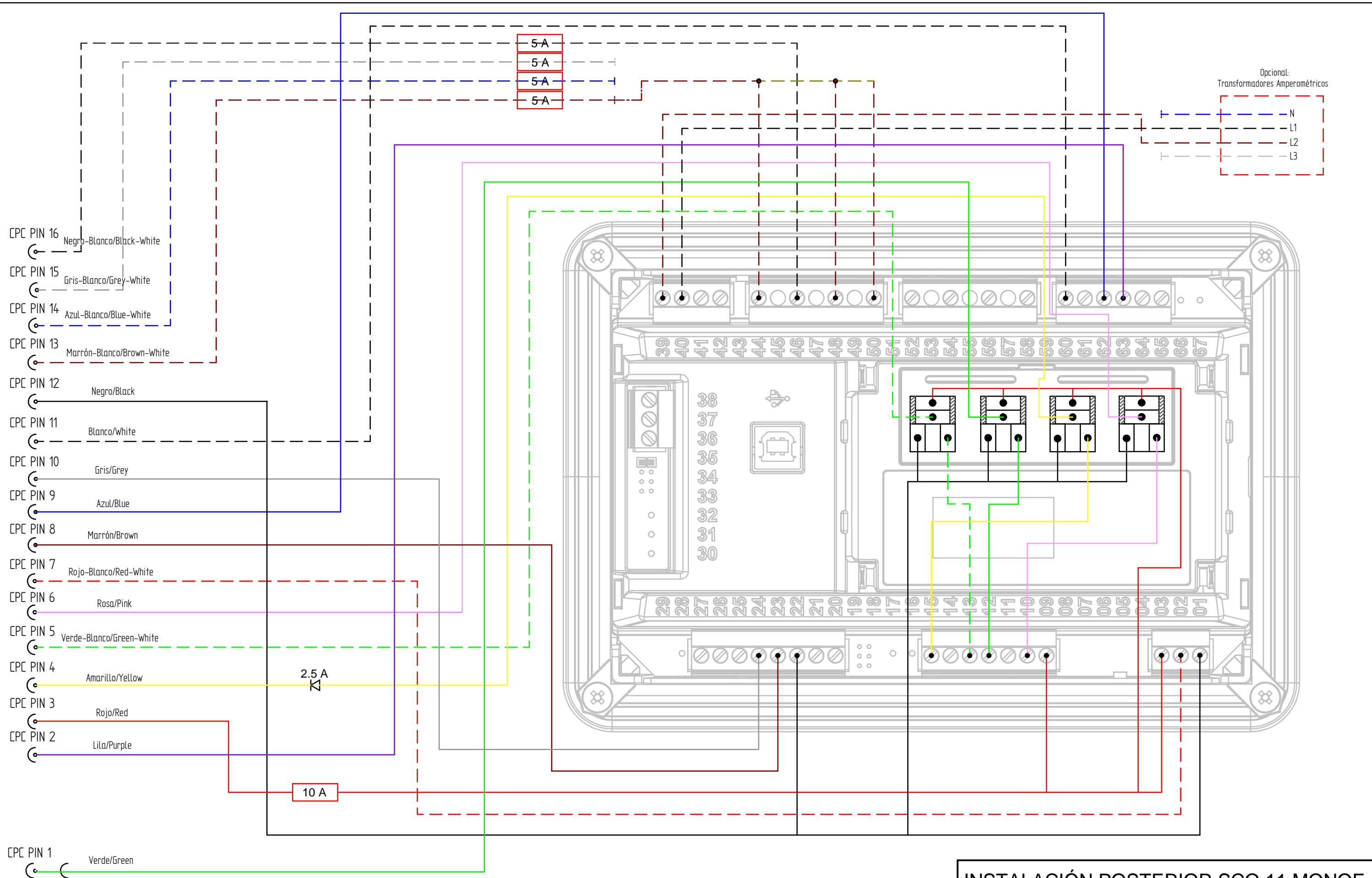

Revisión A

1. Cable amarillo de T11 (BO2) al T15 (BO6) (Fuel/Stop Solenoid)
2. Cable lila que estaba desconectado, lo llevamos al T63 (B14) (Paro de emergencia)
3. Se ha cambiado los cables azules de tensión y corriente por los marrones (Bi-Fase)

INSTALACIÓN POSTERIOR SCO 11 MONOF.				
DIBUJADO MARC G.	VERIFICADO RUBEN D.	FECHA CREACIÓN 12/04/2022	ÚLTIMA REVISIÓN 16/09/2022	PÁGINA
 SOLÉ, S.A.		-	A	1

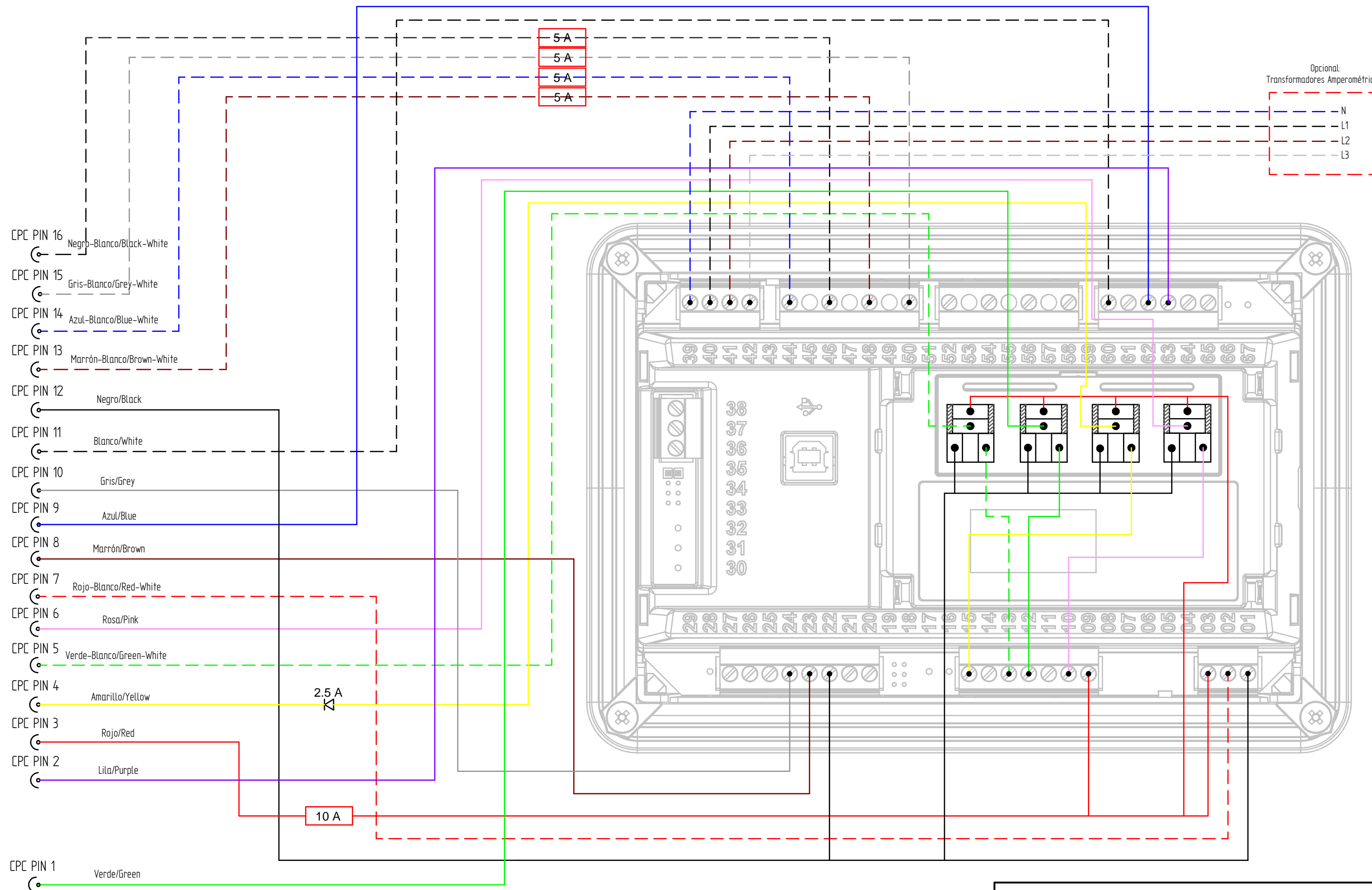

Revisión A

1. Se ha conectado el cable lila que estaba desconectado, a la T63 (BI4) (Paro de emergencia)
2. Se ha cambiado el cable amarillo de la BO2 a la BO6

INSTALACIÓN POSTERIOR SCO 11 TRIF.				
DIBUJADO MARC G.	VERIFICADO RUBEN D.	FECHA CREACIÓN 12/04/2022	ÚLTIMA REVISIÓN 16/09/2022	PÁGINA
 SOLÉ, S.A.		-	A	1



Section 10 – Overall dimensions

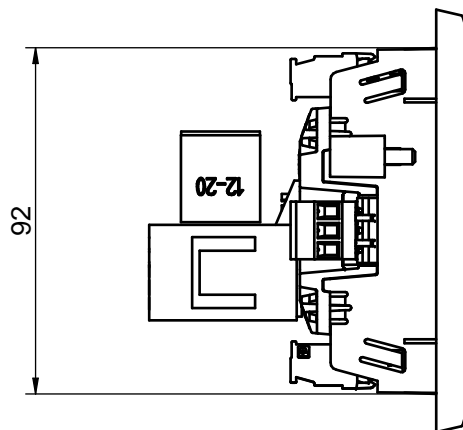
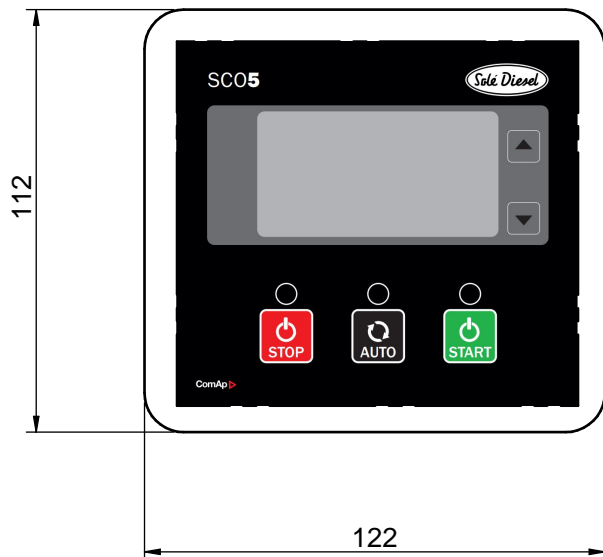
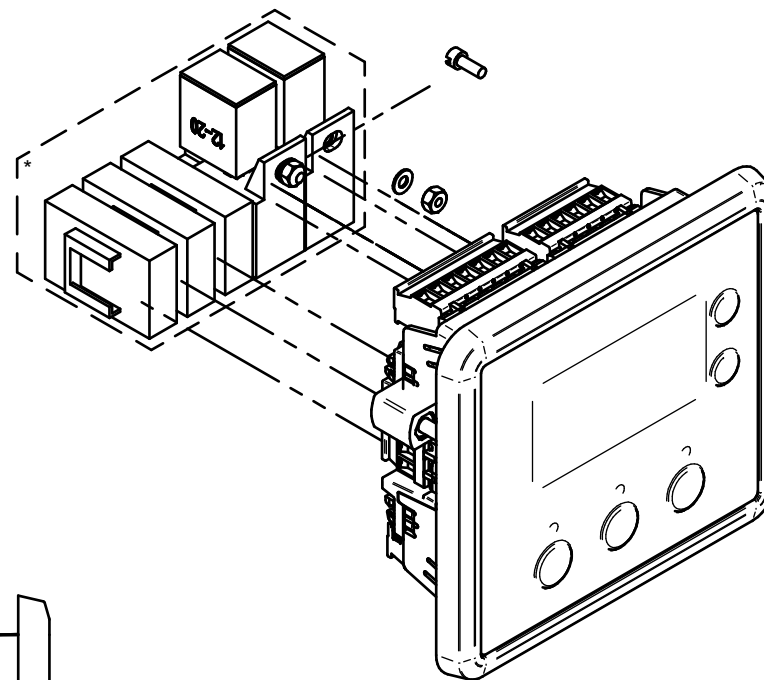
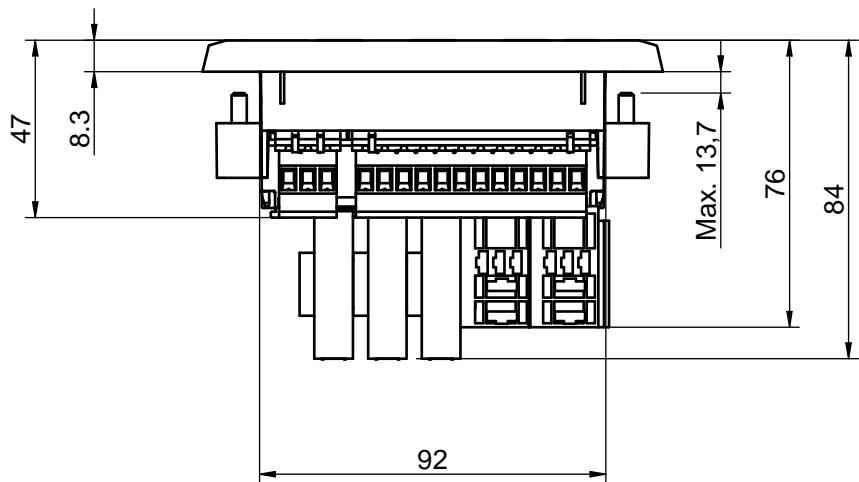

Medidas Nominales (mm)		PANEL COMAP SCO5 SOLÉ				
0	100	SCO 5 PANEL				
a	30	MATERIAL	ACABADO	TRATAMIENTO	PRESENTACIÓN	ESCALA
6	100	--	--	--	--	/.
0	300	DIBUJADO	VERIFICADO	GRADO PRECISIÓN	FECHA CREACIÓN	ÚLTIMA REVISIÓN
a	6	VICTORG	P.IGLESIAS	MEDIO	26/07/2022	01/03/2023
Grado de Precisión DIN-7168	Fino	Sole Diesel		SOLÉ, S.A.	61972100S	
	Medio					
	Bastio					

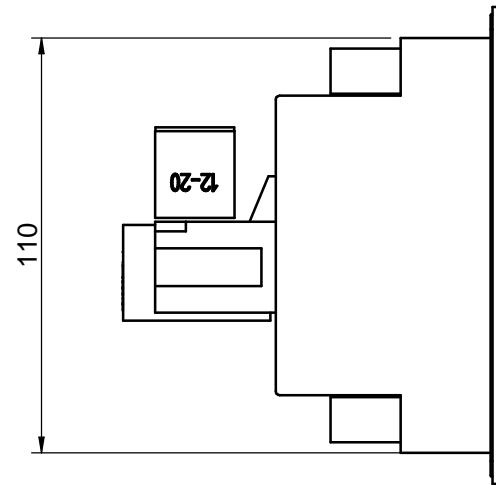
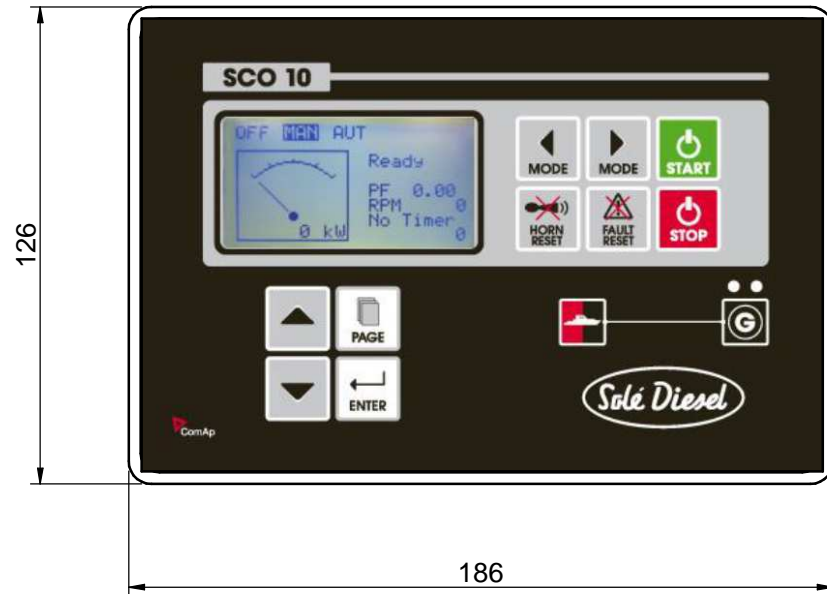
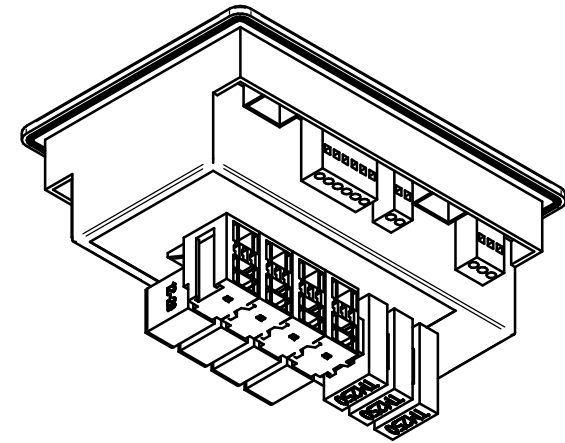
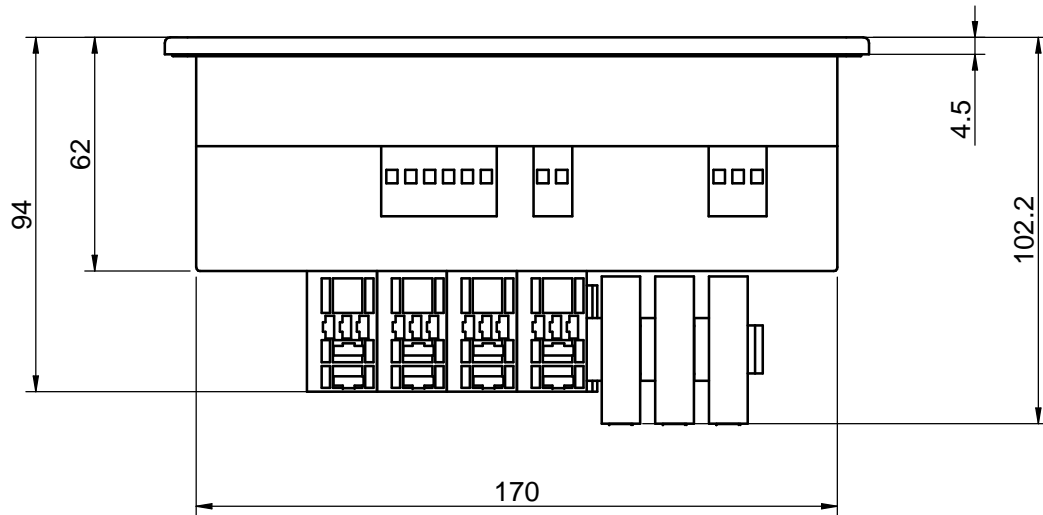

Medidas Nominales (mm)	100	PANEL SCO 10				
	a 300	BASADO EN CONFIGURACION 60973400S				
6	a 30	MATERIAL	ACABADO	TRATAMIENTO	PRESENTACION	ESCALA
0	a 6	DIBUJADO	VERIFICADO	GRADO PRECISION	FECHA CREACION	ULTIMA REVISION
		P.IGLESIAS		MEDIO	16/12/2016	--
Grado de Precisión DIN-7168	Fino ±0.05 Medio ±0.1 Bastio ±0.2	Solé Diesel		SOLÉ, S.A.	3002	

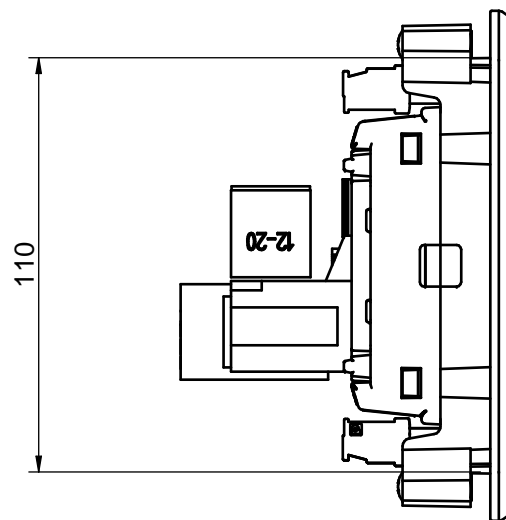
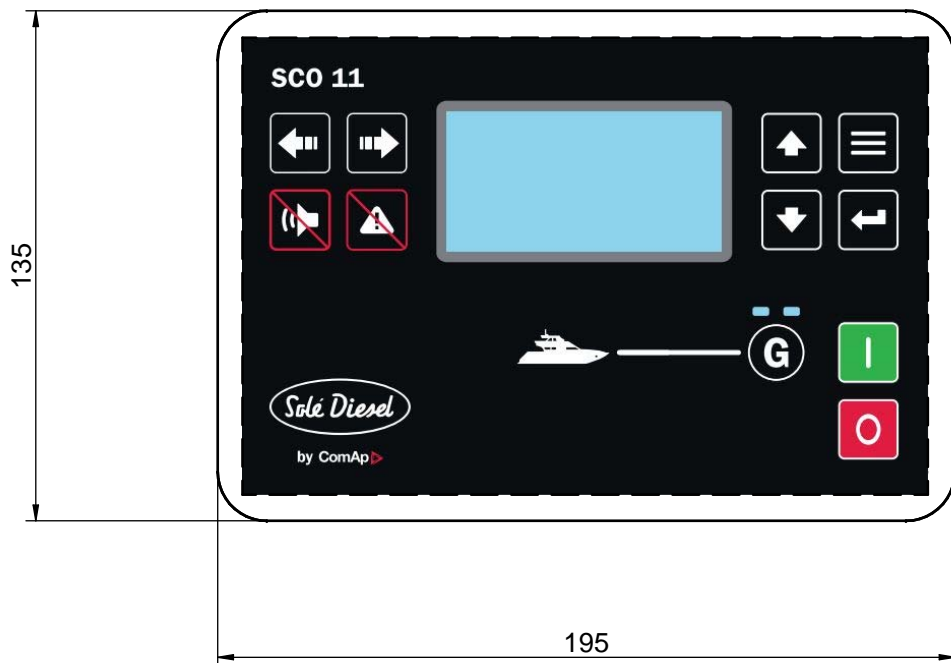
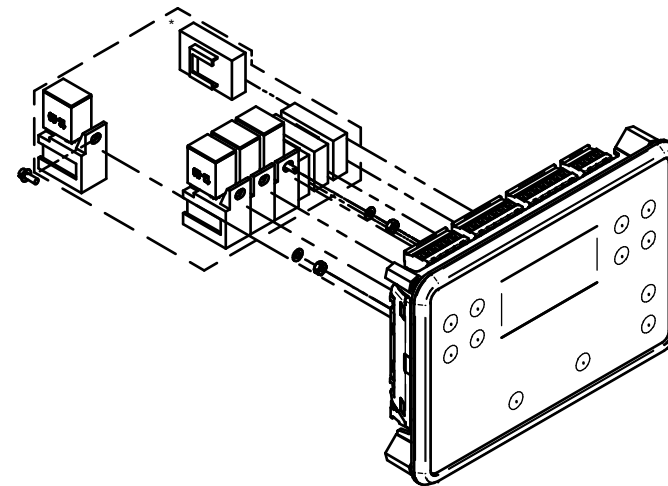
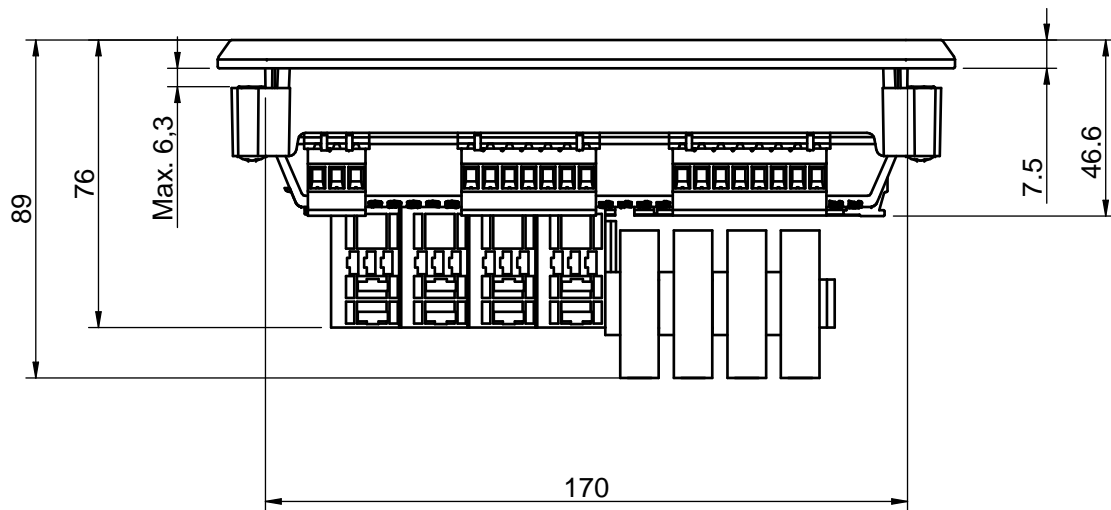

Medidas Nominales (mm)		PANEL COMAP SCO 11 SOLÉ				
0	100	SCO 11 PANEL				
a	30	MATERIAL	ACABADO	TRATAMIENTO	PRESENTACIÓN	ESCALA
6	100	--	--	--	--	/.
0	30	DIBUJADO	VERIFICADO	GRADO PRECISIÓN	FECHA CREACIÓN	ÚLTIMA REVISIÓN
a	6	VICTORG	P.IGLESIAS	MEDIO	26/07/2022	01/03/2023
Grado de Precisión DIN-7168	Fino	Sole Diesel		SOLÉ, S.A.	62972100S	
	Medio					
	Bastio					



MOTORES MARINOS · GRUPOS ELECTRÓGENOS · HÉLICES · ACCESORIOS

C-243 b, km 2 · 08760 Martorell (Barcelona)
Tel. +34 93 775 14 00 · Fax +34 93 775 30 13
www.solédiesel.com · info@solédiesel.com

Síguenos en:



© Copyright 2019 Solé Diesel. Todos los derechos reservados. Los textos y las especificaciones están sujetas a cambios sin previo aviso y sin ninguna obligación o responsabilidad alguna.



U_CTSC0520_EN
Revision 1
06/2022