

DATOS TÉCNICOS / TECHNICAL DATA

(1) Manguera entrada agua salada / Sea water hose intake: Ø20mm
 (2) Manguera entrada combustible / Fuel hose intake: Ø8mm
 (3) Manguera retorno combustible / Diesel Fuel return hose: Ø5mm

Medidas Nominales (mm)	100	KIT 13810048 + MINI-29 v6 CON COLA VOLVO 100S				
	30	KIT 13810048 + MINI-29 v6 WITH DRIVE VOLVO 100S				
Grado de Precisión DIN-7168	0 a 6	±0.05	±0.1	±0.15	±0.2	±0.5
	Fino	±0.1	±0.2	±0.3	±0.5	±1.2
	Medio	±0.2	±0.3	±0.5	±0.8	±1.2
	Bastio	±0.2	±0.5	±0.8	±1.2	±1.2
MATERIAL		ACABADO		TRATAMIENTO	PRESENTACIÓN	ESCALA
DIBUJADO P.IGLESIAS		VERIFICADO		GRADO PRECISIÓN MEDIO	Suavizar aristas	/.
FECHA CREACIÓN		ÚLTIMA REVISIÓN				
04/04/2018		--				
		SOLE, S.A.		13810048+17635000.6+17610102.6		

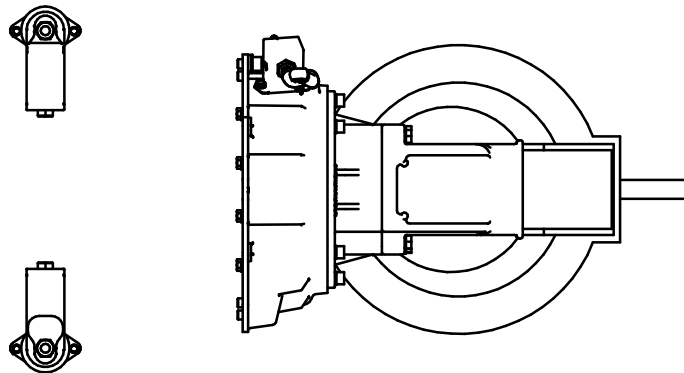
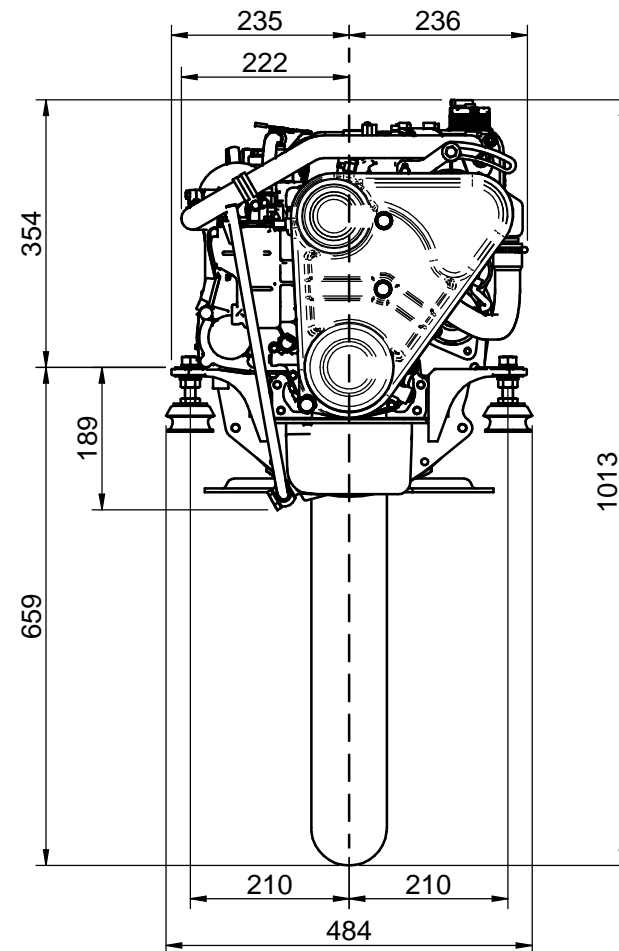
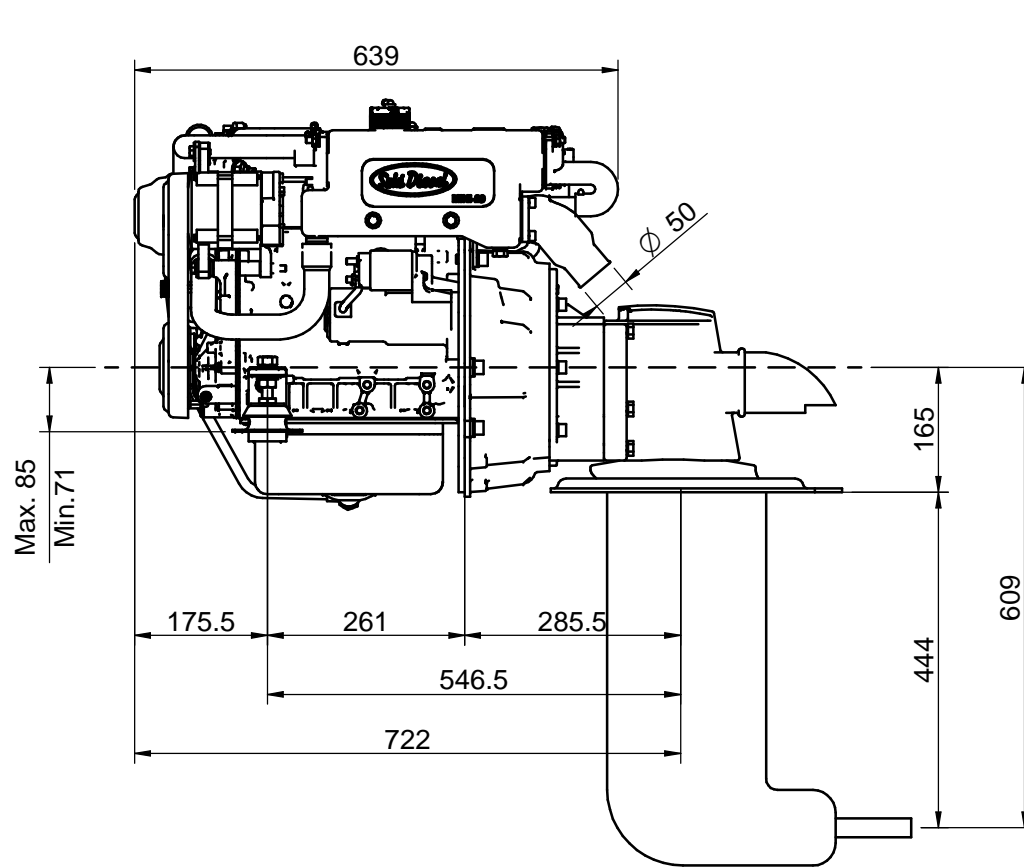

DATOS TÉCNICOS / TECHNICAL DATA

- (1) Manguera entrada agua salada / Sea water hose intake: Ø20mm
- (2) Manguera entrada combustible / Fuel hose intake: Ø8mm
- (3) Manguera retorno combustible / Diesel Fuel return hose: Ø5mm

Medidas Nominales (mm)	100	KIT 13810048 + MINI-29 v6 CON COLA VOLVO 110S								
	300	KIT 13810048 + MINI-29 v6 WITH DRIVE VOLVO 110S								
Grado de Precisión DIN-7168	0 a 6	Fino ±0.05	Medio ±0.1	Bastio ±0.2	100 a 300	±0.15	±0.2	±0.5	±0.8	±1.2
MATERIAL	ACABADO	TRATAMIENTO	PRESENTACIÓN	ESCALA						
DIBUJADO P.IGLESIAS	VERIFICADO	GRADO PRECISIÓN MEDIO	FECHA CREACIÓN 04/04/2018	PRESENTACIÓN Suavizar aristas	ESCALA ./.					
ÚLTIMA REVISIÓN	--									
		SOLE, S.A.			13810048+17635000.6+17610111.6					

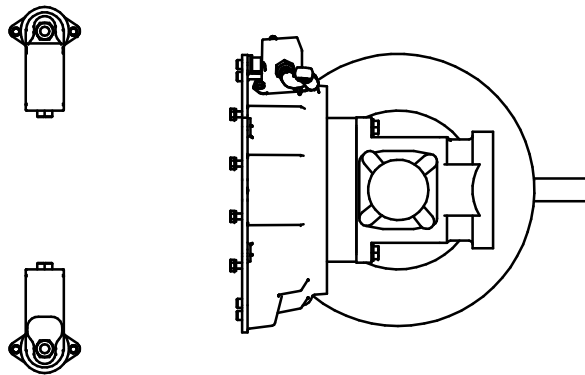
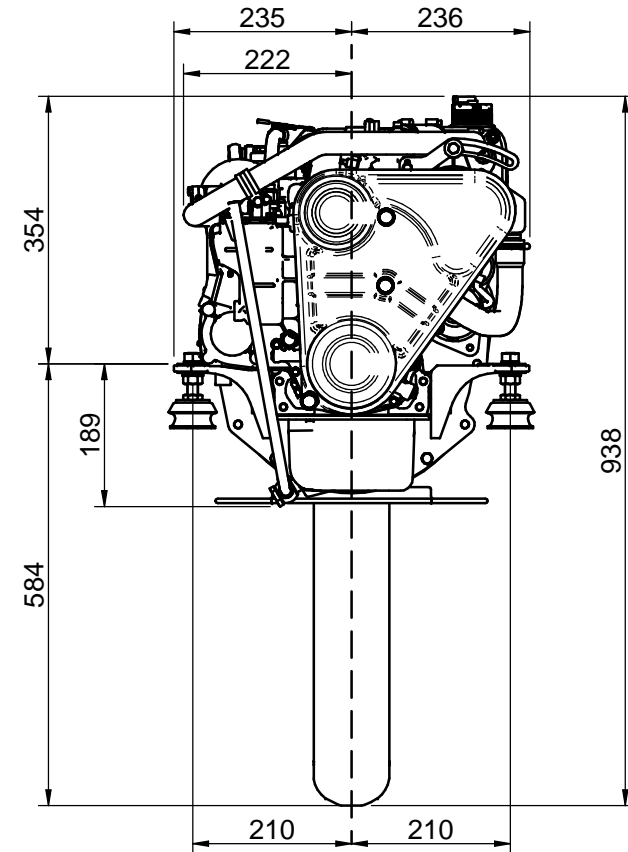
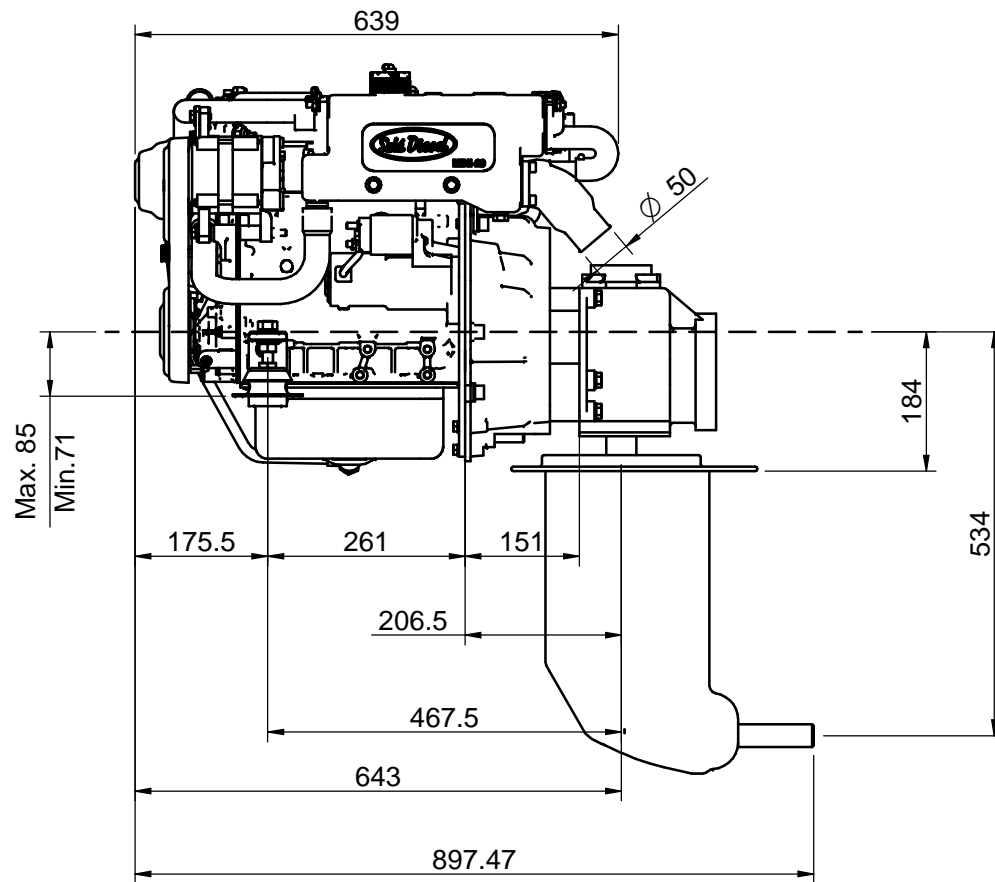

DATOS TÉCNICOS / TECHNICAL DATA

- (1) Manguera entrada agua salada / Sea water hose intake: $\varnothing 20\text{mm}$
- (2) Manguera entrada combustible / Fuel hose intake: $\varnothing 8\text{mm}$
- (3) Manguera retorno combustible / Diesel Fuel return hose: $\varnothing 5\text{mm}$

Medidas Nominales (mm)	100	KIT 13810048 + MINI-29 v6 CON COLA VOLVO 120BS/SC/SE				
	30 a 300	KIT 13810048 + MINI-29 v6 WITH DRIVE VOLVO 120BS/SC/SE				
6 a 6	30	MATERIAL	ACABADO	TRATAMIENTO	PRESENTACIÓN	ESCALA
					Suavizar aristas	/.
0 a 0	6	DIBUJADO	VERIFICADO	GRADO PRECISIÓN	FECHA CREACIÓN	ÚLTIMA REVISIÓN
		P.IGLESIAS		MEDIO	04/04/2018	--
Grado de Precisión DIN-7168	Fino ± 0.05 Medio ± 0.1 Bastio ± 0.2			SOLE, S.A.		13810048 +17635000.6+17610120.6

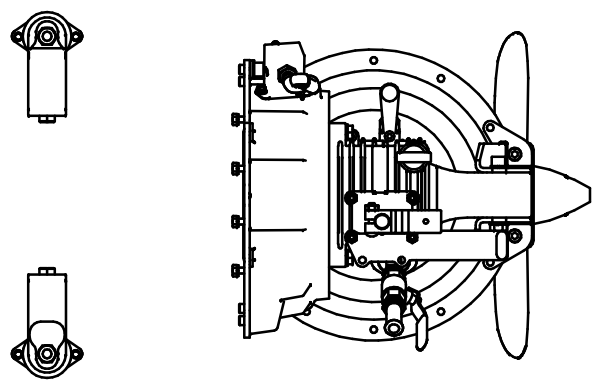
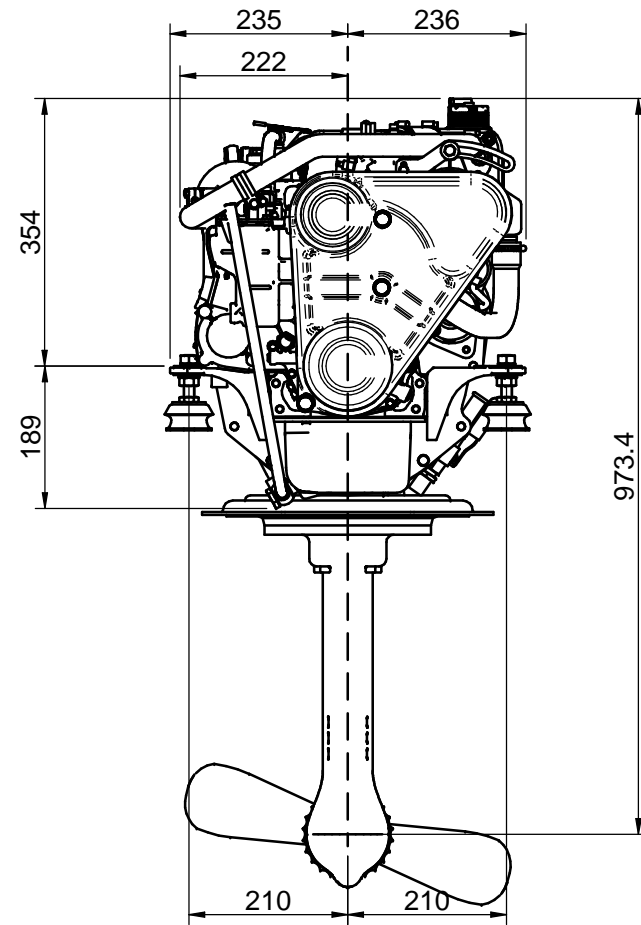
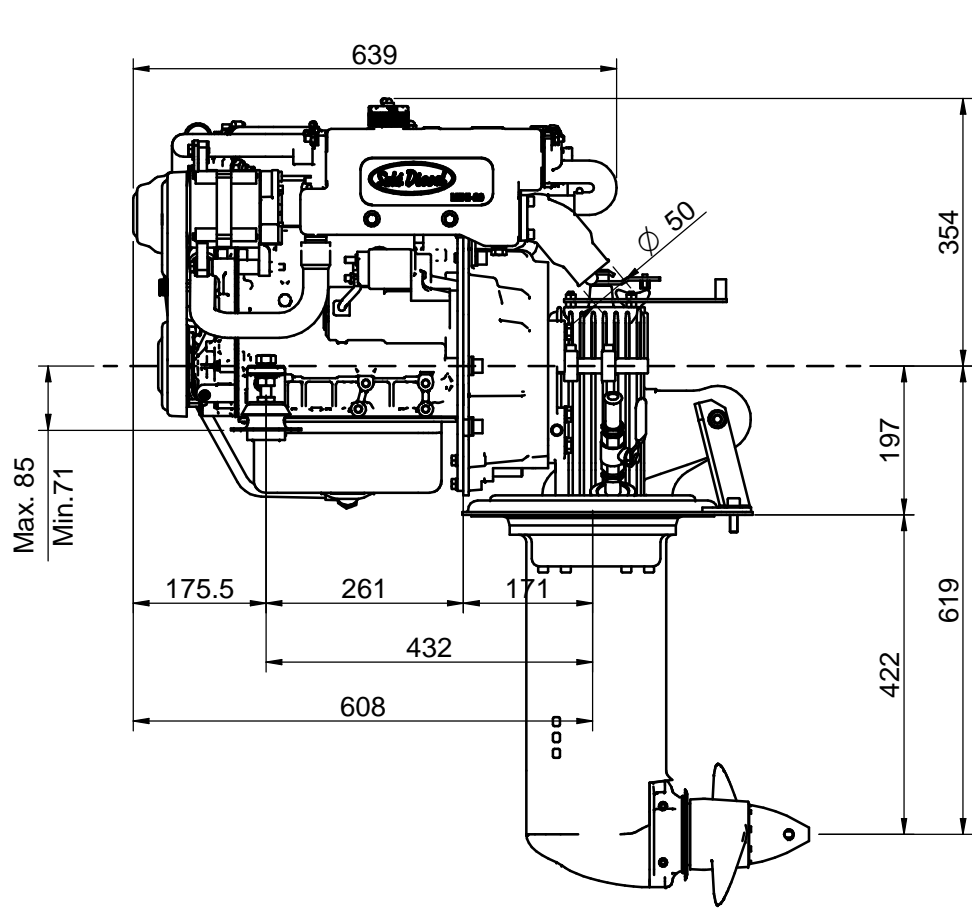

DATOS TÉCNICOS / TECHNICAL DATA

(1) Manguera entrada agua salada / Sea water hose intake: Ø20mm
 (2) Manguera entrada combustible / Fuel hose intake: Ø8mm
 (3) Manguera retorno combustible / Diesel Fuel return hose: Ø5mm

Medidas Nominales (mm)		100	KIT 13810048 + MINI-29 v6 CON COLA VOLVO 130S			
		30	KIT 13810048 + MINI-29 v6 WITH DRIVE VOLVO 130S			
		6	MATERIAL	ACABADO	TRATAMIENTO	PRESENTACIÓN
		0	Suavizar aristas		ESCALA	
		0	/.			
		6	DIBUJADO	VERIFICADO	GRADO PRECISIÓN	FECHA CREACIÓN
		6	MEDIO		ÚLTIMA REVISIÓN	
		6	P.IGLESIAS		04/04/2018	
		6	--			
Grado de Precisión DIN-7168		Fino ±0.05	SOLE, S.A.		13810048+17635000.6+17610100.6	
		Medio ±0.1	SOLE, S.A.			
		Bastio ±0.2	SOLE, S.A.			



SOLE, S.A.

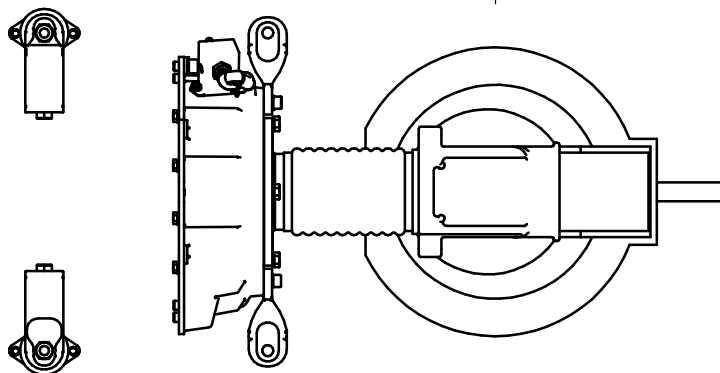
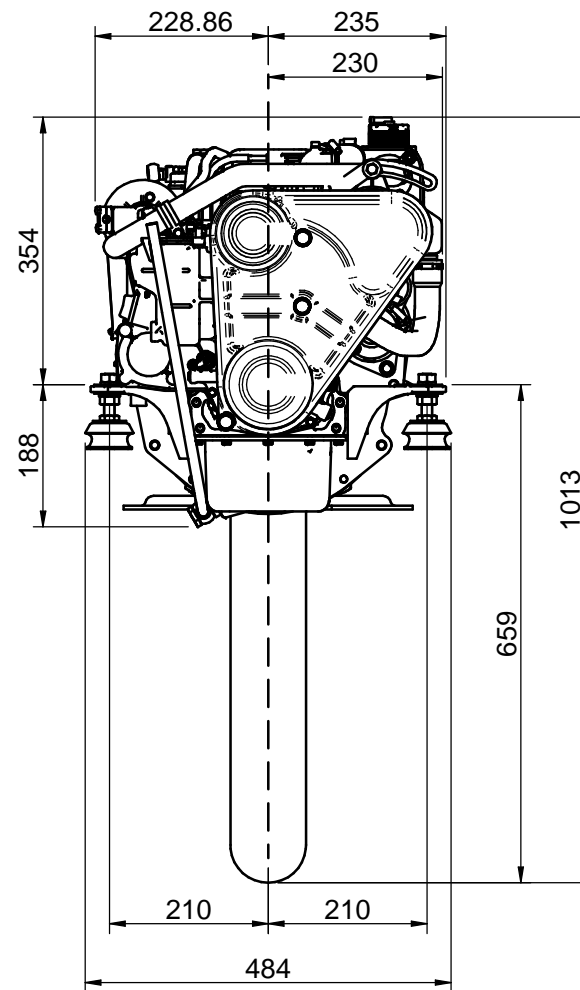
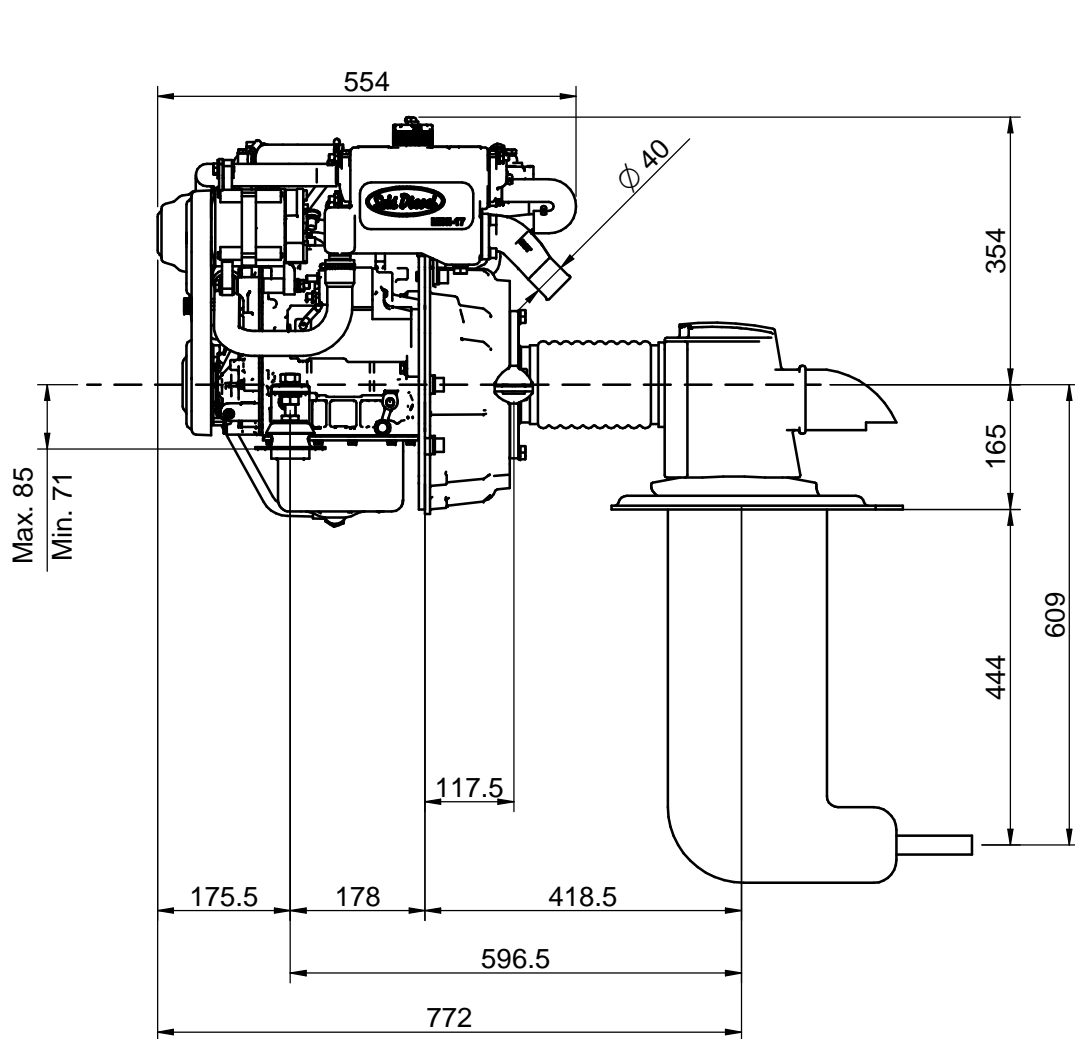

DATOS TÉCNICOS / TECHNICAL DATA

Manguera entrada agua salada / Sea water hose intake: Ø20mm
 Manguera entrada combustible / Fuel hose intake: Ø8mm
 Manguera retorno combustible / Diesel Fuel return hose: Ø5mm

Medidas Nominales (mm)		100	KIT 13810048 + MINI-17 v6 KIT COLA VOLVO 100S				
		30	KIT 13810048 + MINI-17 v6 SDRIVE VOLVO 100S				
		6	MATERIAL	ACABADO	TRATAMIENTO	PRESENTACIÓN	ESCALA
		0			Suavizar aristas	/.	/.
		6	DIBUJADO	VERIFICADO	GRADO PRECISIÓN	FECHA CREACIÓN	ÚLTIMA REVISIÓN
		6	P.IGLESIAS		MEDIO	04/04/2018	--
Grado de Precisión DIN-7168		Fino ±0.05			SOLE, S.A.		13810048 +13835000.6+13810102.6
		Medio ±0.1					
		Bastio ±0.2					
		±0.1					
		±0.2					
		±0.3					
		±0.5					
		±0.8					
		±1.2					

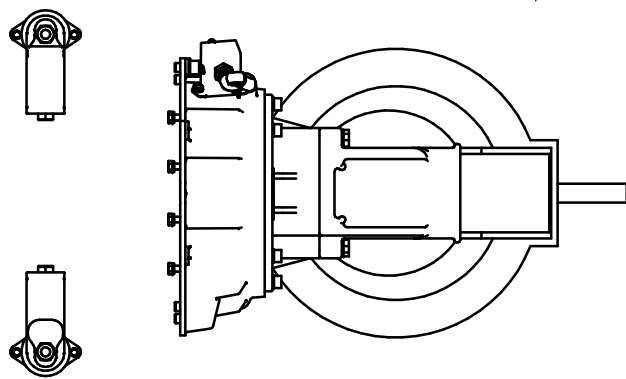
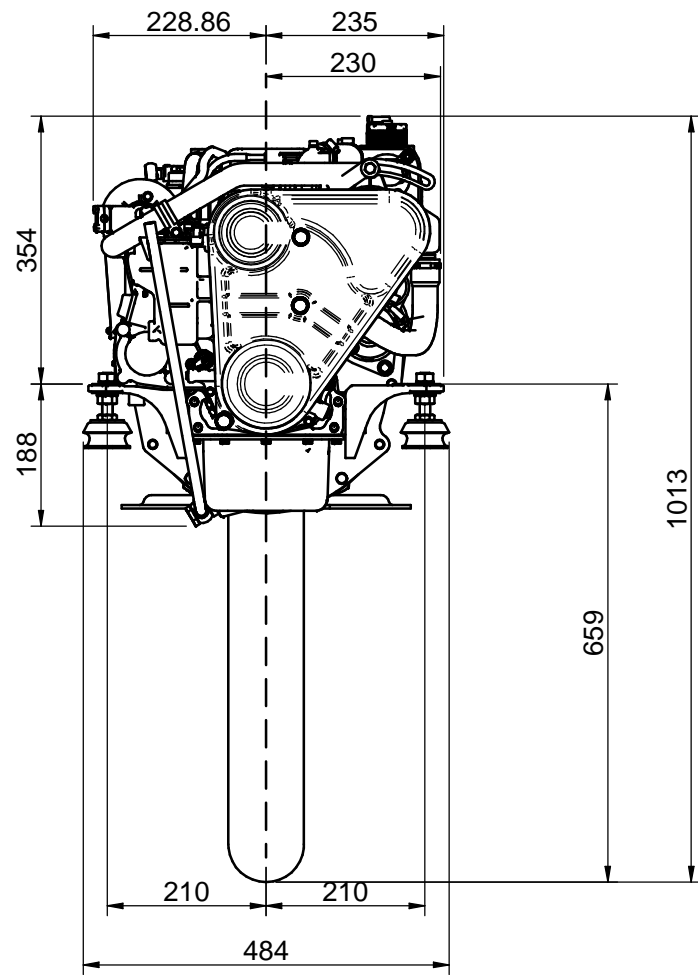
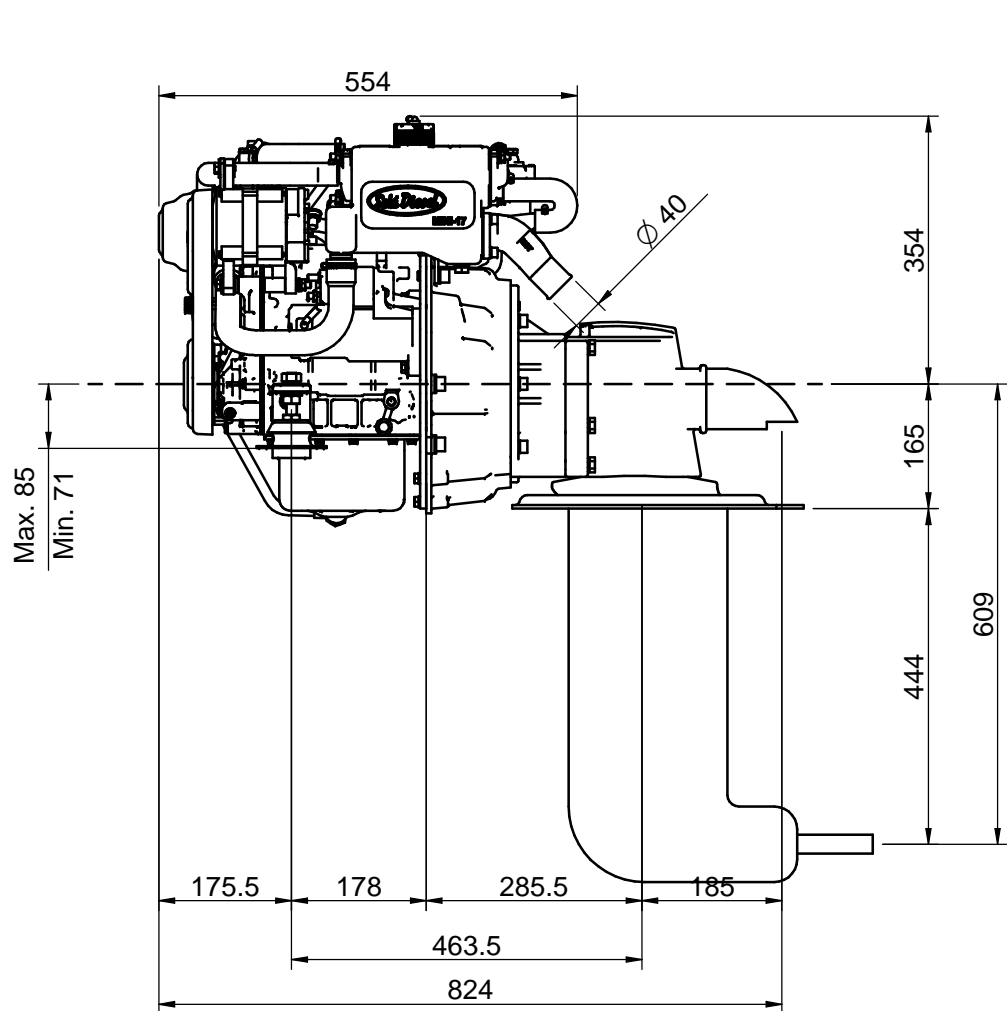

DATOS TÉCNICOS / TECHNICAL DATA

Manguera entrada agua salada / Sea water hose intake: Ø20mm
 Manguera entrada combustible / Fuel hose intake: Ø8mm
 Manguera retorno combustible / Diesel Fuel return hose: Ø5mm

Medidas Nominales (mm)		100	KIT 13810048 + MINI-17 v6 KIT COLA VOLVO 110S			
		30	KIT 13810048 + MINI-17 v6 SDRIVE VOLVO 110S			
		6	MATERIAL	ACABADO	TRATAMIENTO	PRESENTACIÓN
		0	Suavizar aristas		ESCALA	
		0	/.			
		6	DIBUJADO	VERIFICADO	GRADO PRECISIÓN	FECHA CREACIÓN
		0	P.IGLESIAS		MEDIO	ÚLTIMA REVISIÓN
		6			04/04/2018	--
Grado de Precisión DIN-7168		Fino			SOLE, S.A.	
		Medio			13810048+13835000.6+13810111.6	
		Bastio				

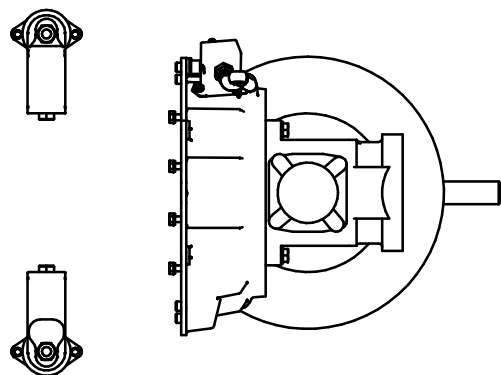
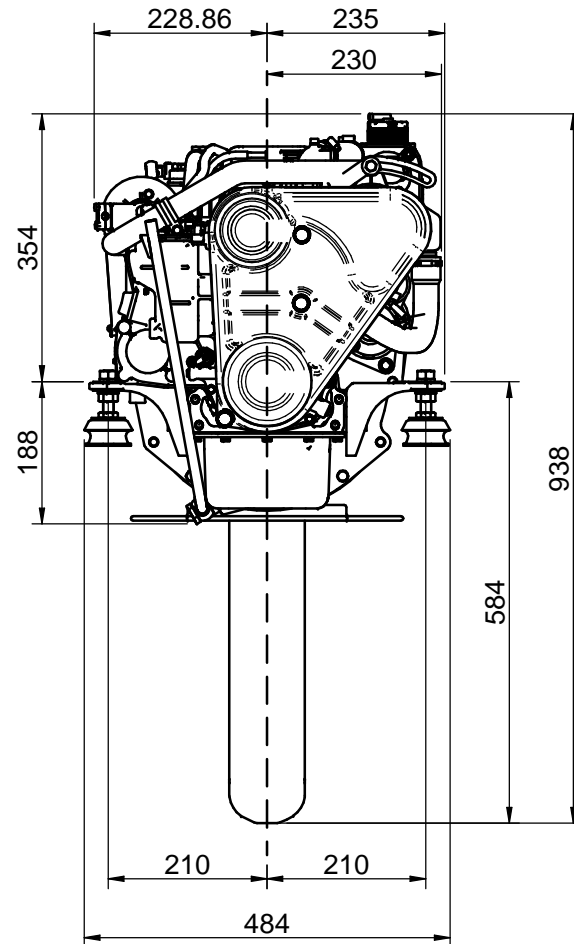
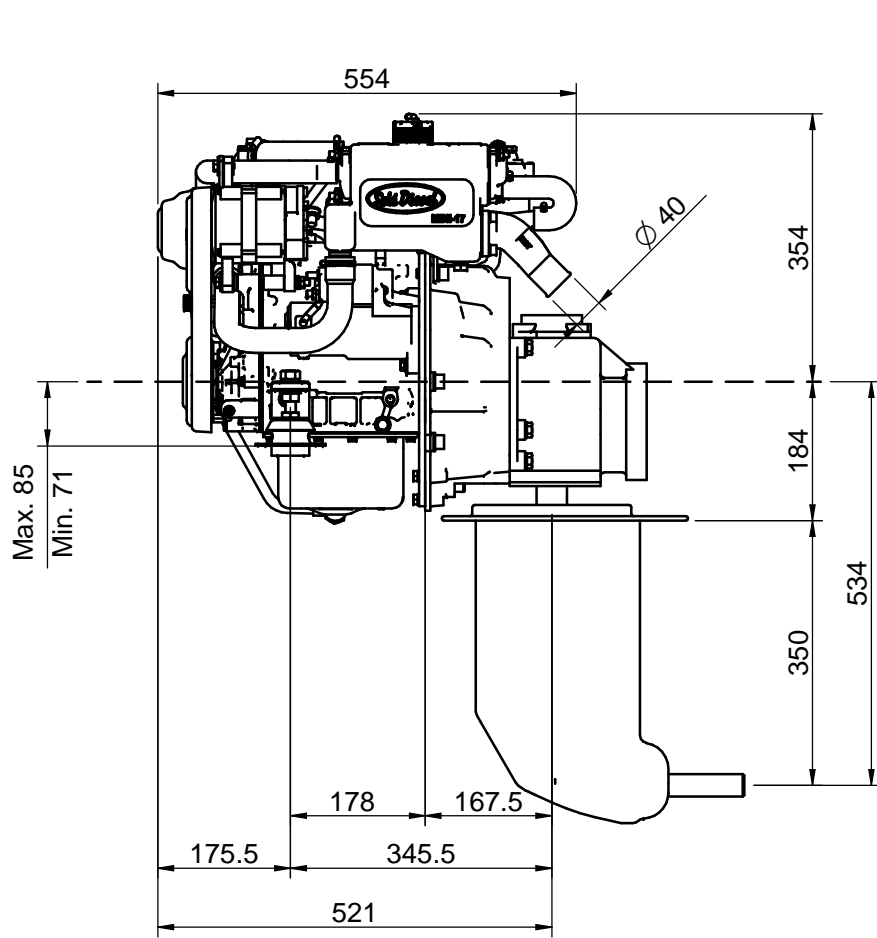

DATOS TÉCNICOS / TECHNICAL DATA

Manguera entrada agua salada / Sea water hose intake: Ø20mm
 Manguera entrada combustible / Fuel hose intake: Ø8mm
 Manguera retorno combustible / Diesel Fuel return hose: Ø5mm

Medidas Nominales (mm)	100	KIT 13810048 + MINI-17 v6 KIT COLA VOLVO 120BS/SC/SE				
	30	KIT 13810048 + MINI-17 v6 SDRIVE VOLVO 120BS/SC/SE				
a	100	MATERIAL	ACABADO	TRATAMIENTO	PRESENTACIÓN	ESCALA
6	30				Suavizar aristas	/.
0	6	DIBUJADO	VERIFICADO	GRADO PRECISIÓN	FECHA CREACIÓN	ÚLTIMA REVISIÓN
Grado de Precisión DIN-7168	Fino ±0.05 Medio ±0.1 Bastio ±0.2	P.IGLESIAS		MEDIO	04/04/2018	--
				SOLE, S.A.		13810048+13835000.6+13810100.6

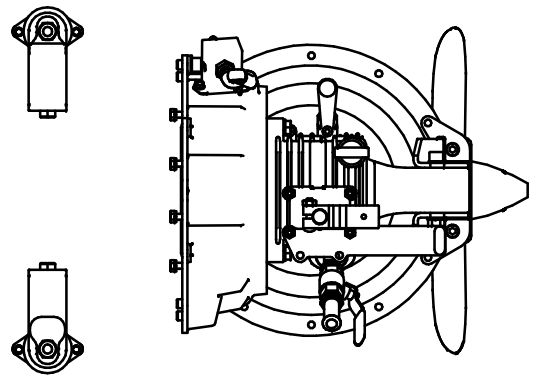
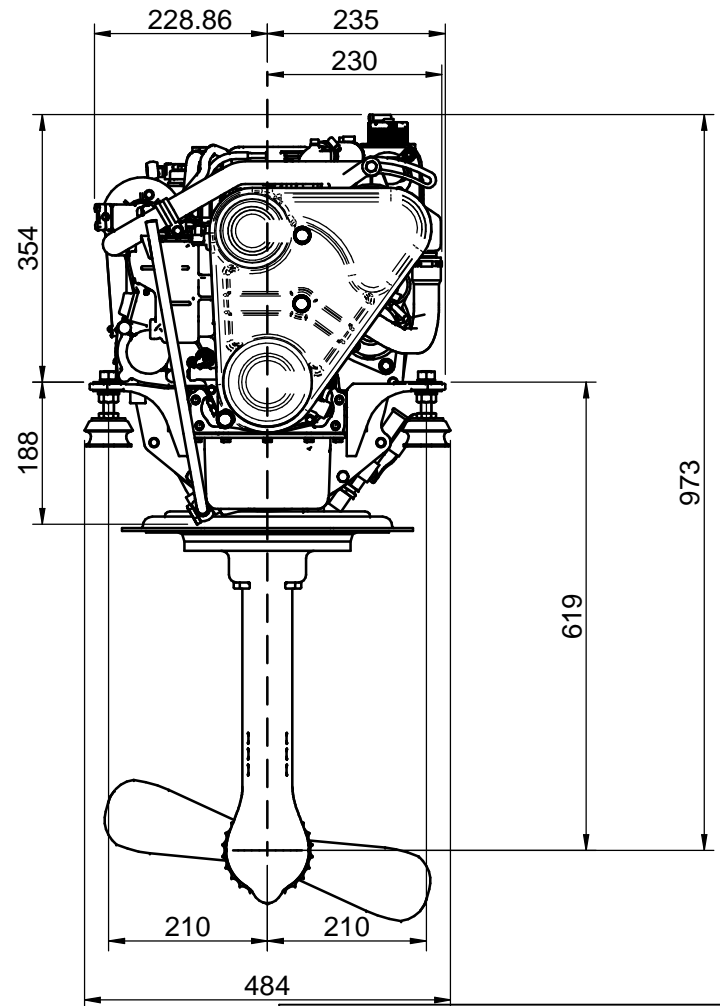
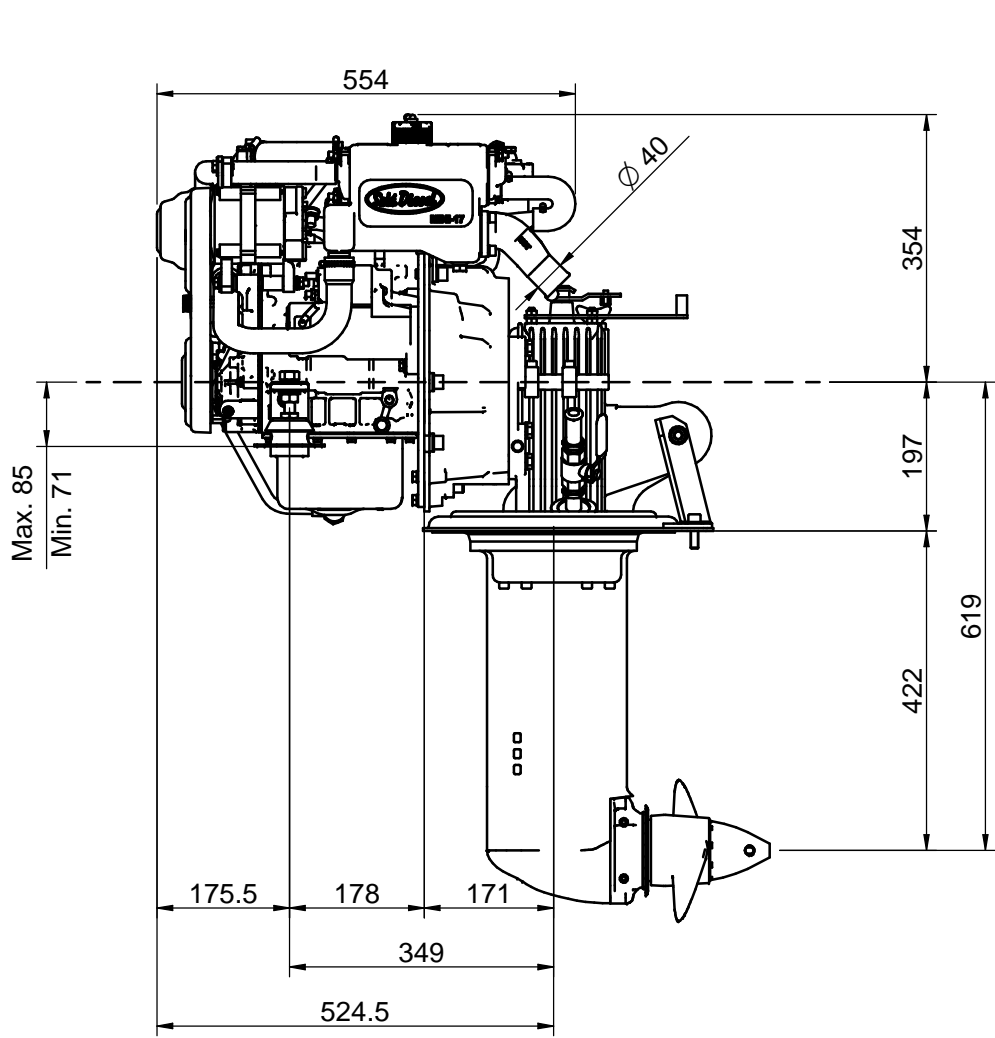

DATOS TÉCNICOS / TECHNICAL DATA

Manguera entrada agua salada / Sea water hose intake: Ø20mm
 Manguera entrada combustible / Fuel hose intake: Ø8mm
 Manguera retorno combustible / Diesel Fuel return hose: Ø5mm

Medidas Nominales (mm)		100	KIT 13810048 + MINI-17 v6 KIT COLA VOLVO 130S			
		30	KIT 13810048 + MINI-17 v6 SDRIVE VOLVO 130S			
		6	MATERIAL	ACABADO	TRATAMIENTO	PRESENTACIÓN
		0	Suavizar aristas		ESCALA	
		6	/.		/.	
		0	DIBUJADO	VERIFICADO	GRADO PRECISIÓN	FECHA CREACIÓN
		6	P.IGLESIAS	MEDIO	04/04/2018	ÚLTIMA REVISIÓN
		±0.05			--	
		±0.1				
		±0.2				
		±0.5				
		±0.8				
		±1.2				
Grado de Precisión DIN-7168		Fino	SOLE, S.A.		13810048 +13835000.6+13810104.6	
		Medio	SOLE, S.A.			
		Bastio	SOLE, S.A.			