

* No representado en el dibujo / Not shown in the drawing

Nº	Referencia	Descripción	Cant
1	52101259	TORNILLO DIN 931 M8x30 8.8	6
2	53033008	ARANDELA GROWER DIN 127-8 CINCADA	16
3	13810021	SUPLEMENTO ARRASTRE ACOPLAMIENTO	1
4	52102258	TORNILLO M8 x 25 DIN-933	6
5	17610021	ARRASTRE ACOPLAMIENTO COLA 110S	1
6	17610016	CARCASA MOTOR SAE 7	1
7	13810016	SUPLEMENTO COLA VOLVO 110S	1
8	53033010	ARANDELA GROWER Ø10 DIN-127	12
9	52103308	TORNILLO DIN-912 M10x25	6
10	52101310	TORNILLO M10 x 35 DIN 931 8.8	6
11	52102257	TORNILLO DIN 933 M8x20 8.8 CINCADO	4
12	53203357	DIN 912 M12 x 1,25 x 20	4
13	53038012	ARANDELA ESTRIADA Ø12 DIN-6798A	4
14	13814070	BOMBA ALIMENTACIÓN ELECTRICA 12V	1
15	13814072	RACOR	2
16	57000361	ARANDELA	2
17	51030006	ARANDELA PLANA Ø6 DIN125	2
18	52102154	TORNILLO M6x10 DIN 933	2
19	51086015	ABRAZADERA UNA OREJA CON ARO	1
20	13814017.5	TUBO BOMBA ALIMENTACION A FILTRO	1
21*	60900126	TERMINAL AZUL	1
22*	58088283	ABRAZ. PLASTICO 3,6 x 140 NEGRA	1

KIT COLA SDRIVE VOLVO 110S

KIT S-DRIVE VOLVO 110S

MATERIAL	ACABADO	TRATAMIENTO	PRESENTACION	ESCALA
				1:1

DIBUJADO XAVIER	VERIFICADO	GRADO PRECISIÓN MEDIO	FECHA CREACIÓN 02/10/2015	ÚLTIMA REVISIÓN
--------------------	------------	--------------------------	------------------------------	-----------------



SOLE, S.A.

13810111.6

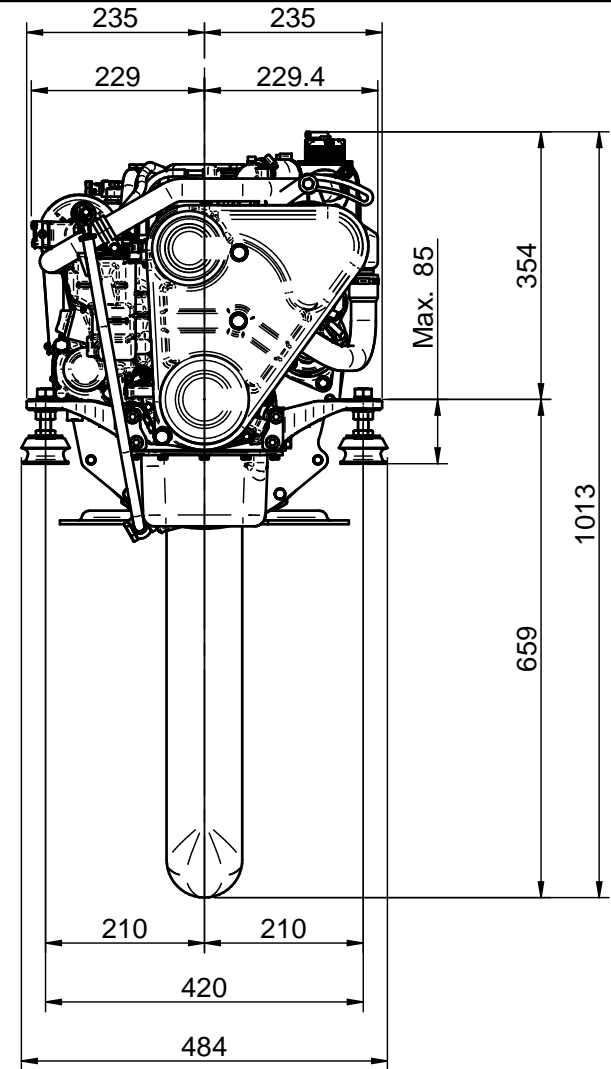
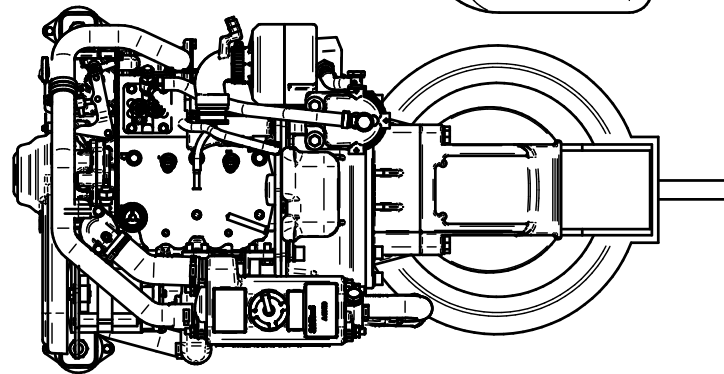
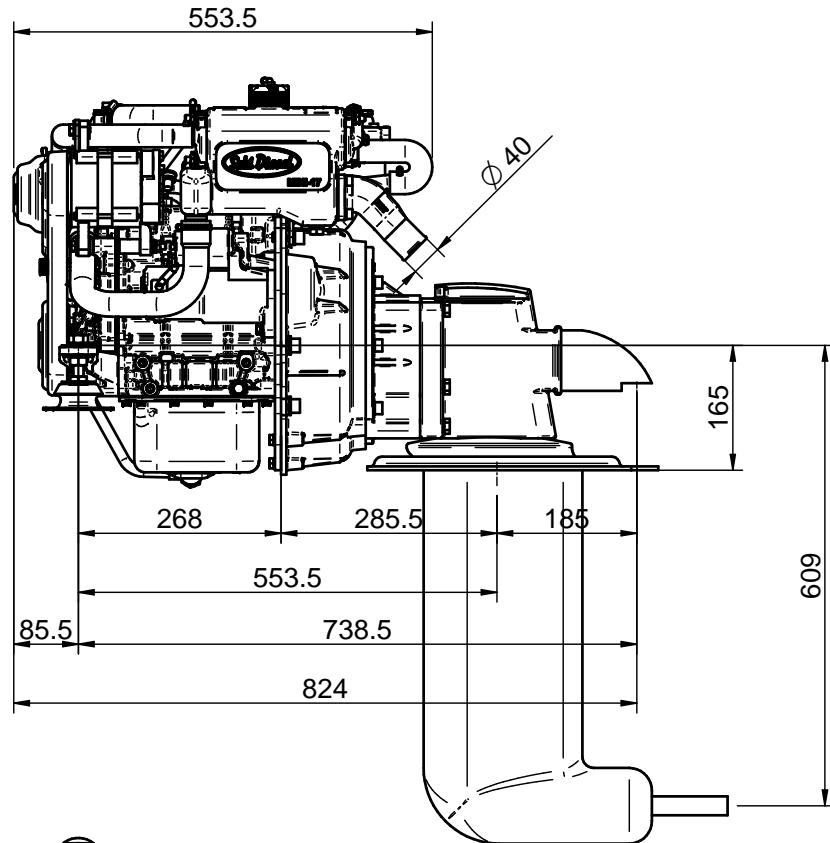

DATOS TÉCNICOS / TECHNICAL DATA

- (1) Manguera entrada agua salada / Sea water hose intake: Ø20mm
- (2) Manguera entrada combustible / Fuel hose intake: Ø8mm
- (3) Manguera retorno combustible / Diesel Fuel return hose: Ø5mm

Medidas Nominales (mm)		MINI-17 v6 CON COLA VOLVO 110S				
Medidas Nominales (mm)		MINI-17 v6 WITH DRIVE VOLVO 110S				
100	a	300	300	300	300	300
30	a	100	100	100	100	100
6	a	30	30	30	30	30
0	a	6	6	6	6	6
Grado de Precisión DIN-7168	Fino	±0.05	±0.1	±0.15	±0.2	±0.2
	Medio	±0.1	±0.2	±0.3	±0.5	±0.5
	Bastio	±0.2	±0.5	±0.8	±1.2	±1.2
		MATERIAL	ACABADO	TRATAMIENTO	PRESENTACIÓN	ESCALA
		DIBUJADO P. IGLESIAS	VERIFICADO	GRADO PRECISIÓN MEDIO	FECHA CREACIÓN 17/02/2017	ÚLTIMA REVISIÓN --
				SOLE, S.A.		13810111.6_MINI17

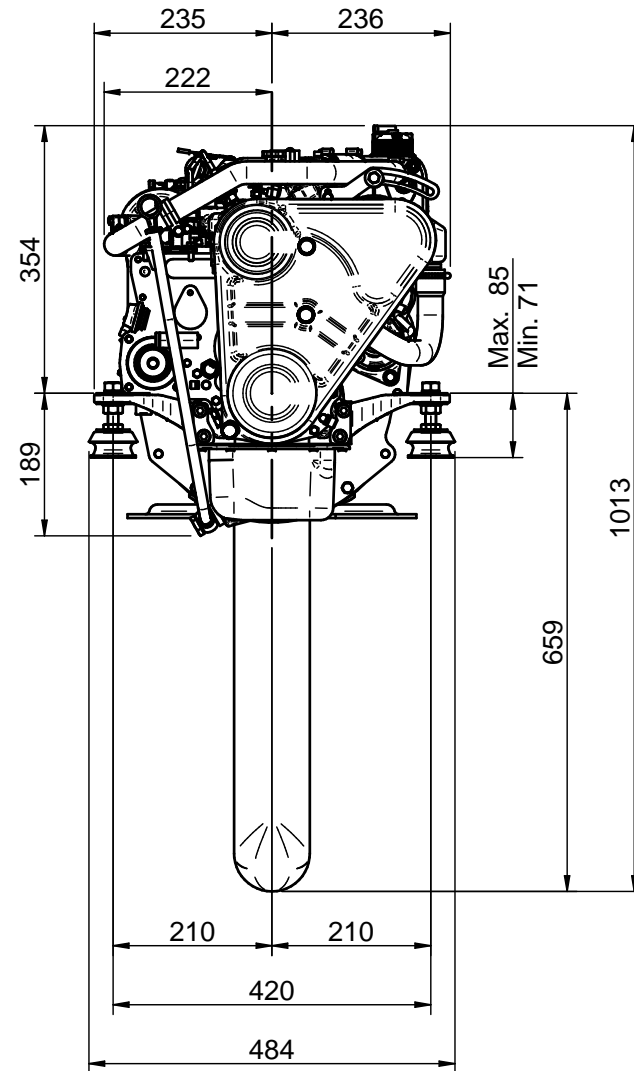
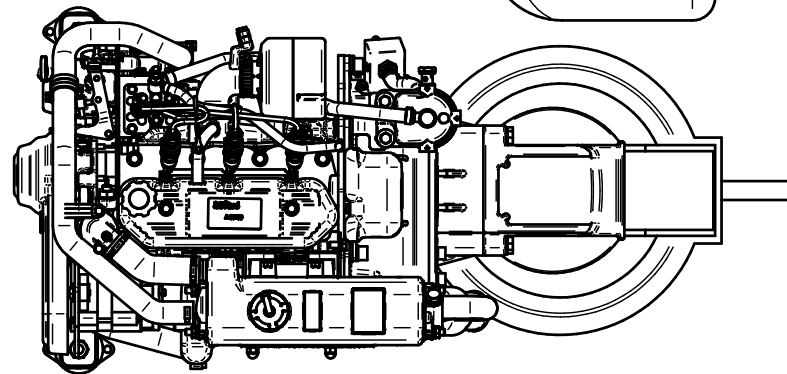
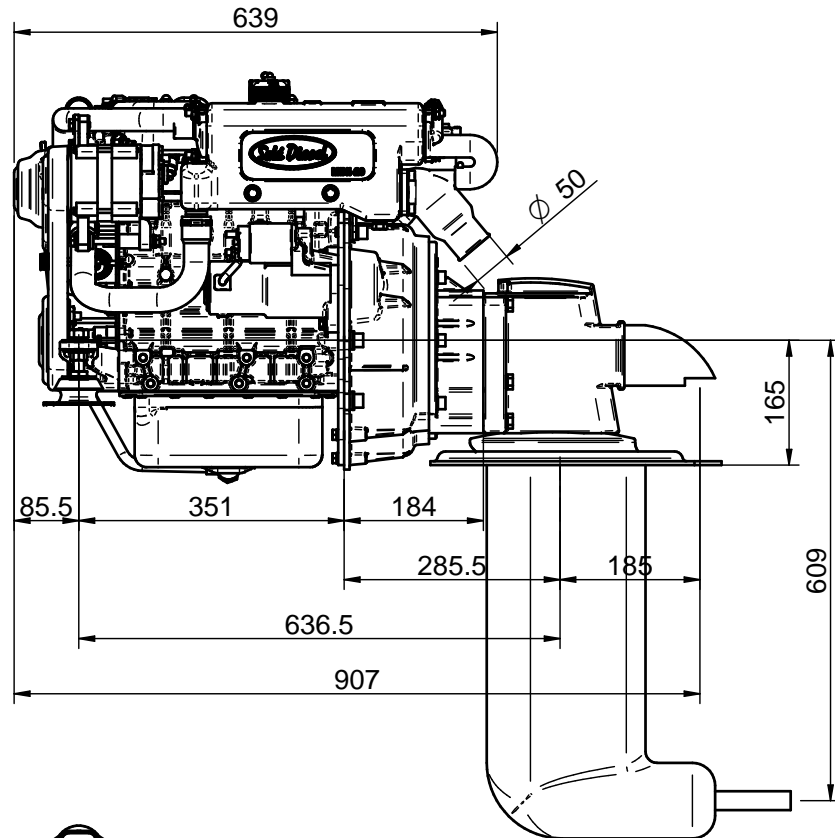

DATOS TÉCNICOS / TECHNICAL DATA

- (1) Manguera entrada agua salada / Sea water hose intake: Ø20mm
- (2) Manguera entrada combustible / Fuel hose intake: Ø8mm
- (3) Manguera retorno combustible / Diesel Fuel return hose: Ø5mm

Medidas Nominales (mm)		MINI-29 v6 CON COLA VOLVO 110S									
Grado de Precisión DIN-7168		MINI-29 v6 WITH DRIVE VOLVO 110S									
0 a 6	±0.05	6 a 30	±0.1	30 a 100	±0.15	100 a 300	±0.2	300 a 1000	±0.3	1000 a 3000	±0.5
Fino	±0.05	Medio	±0.1	Bastio	±0.2						
		MATERIAL		ACABADO		TRATAMIENTO		PRESENTACIÓN		ESCALA	
		DIBUJADO		VERIFICADO		GRADO PRECISIÓN		FECHA CREACIÓN		ÚLTIMA REVISIÓN	
		P.IGLESIAS				MEDIO		17/02/2017		--	
				SOLÉ, S.A.		13810111.6_MINI29					