

CORTE A-A

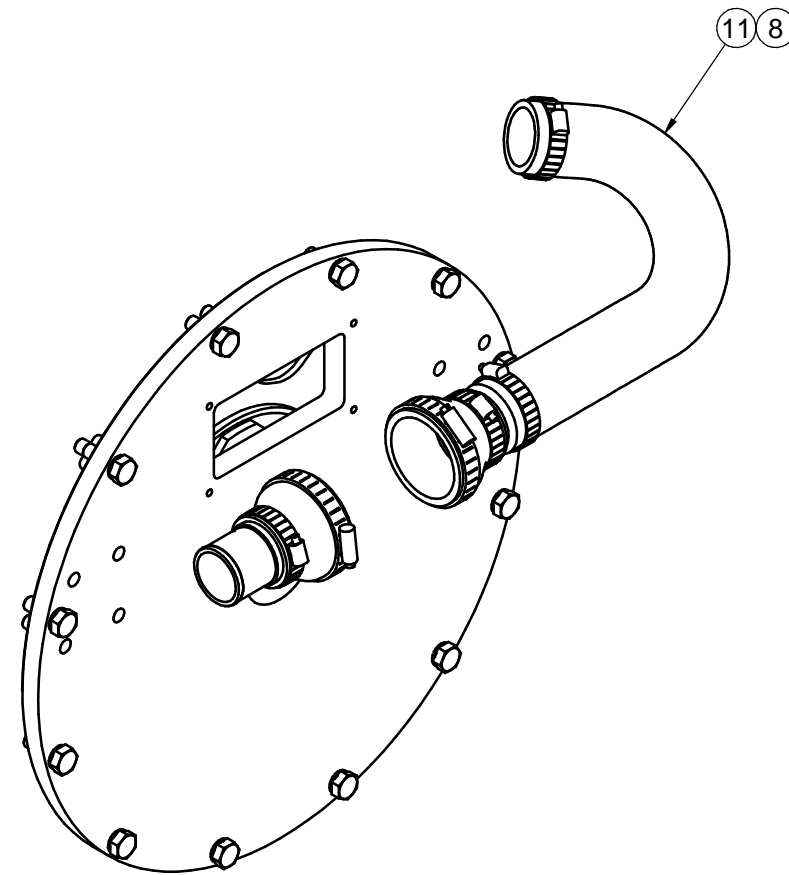

* No mostrado en el dibujo / Not shown in the drawing

Nº	Referencia	Descripción	Material	Cant.
1	16510171	ACOPLAMIENTO ELASTICO		1
2	53038010	ARANDELA ESTRIADA Ø10 DIN-6798A	ACERO	8
3	52103308	TORNILLO DIN-912 M10x25	Acero	8
4	24230022	CARCASA ACOPL. INV. PRM-302 SAE 3		1
5	53033010	ARANDELA GROWER Ø10 DIN-127	ACERO	12
6	52102309	TORNILLO M10x30 DIN 933	Acero	12
7	19411049	MANGUITO	Acero	2
8	54082032	ABRAZADERA 35-50	INOX	4
9	19412002	TAPA REFRIGERADOR	GOMA	2
10	54082050	ABRAZADERA Ø70/50x13 W4 DIN 3017		2
11	19511006	MANGUITO GOMA	GOMA +	1

Medidas Nominales (mm)	100	KIT INVERSOR PRM-302 (SIN REFRIG. ACEITE)			
	300	KIT GEARBOX PRM-302 (WITHOUT OIL COOLER)			
	±0.2	MATERIAL	ACABADO	TRATAMIENTO	PRESENTACION
	±0.15				ESCALA
	±0.1	DIBUJADO	VERIFICADO	GRADO PRECISION	FECHA CREACION
	±0.2	X.MARGARIT	S.SUBACH	MEDIO	06/05/2014
	±0.5			SOLÉ, S.A.	19410212.1