

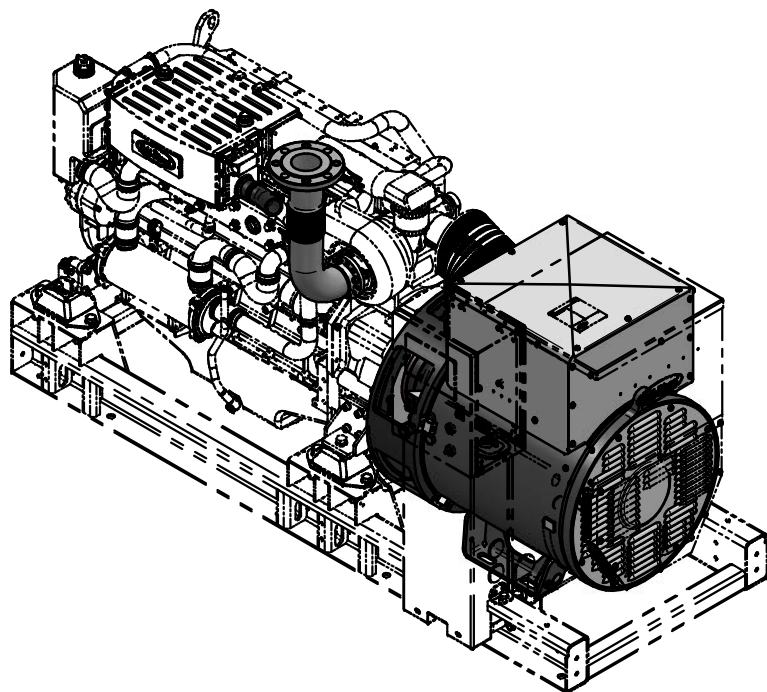

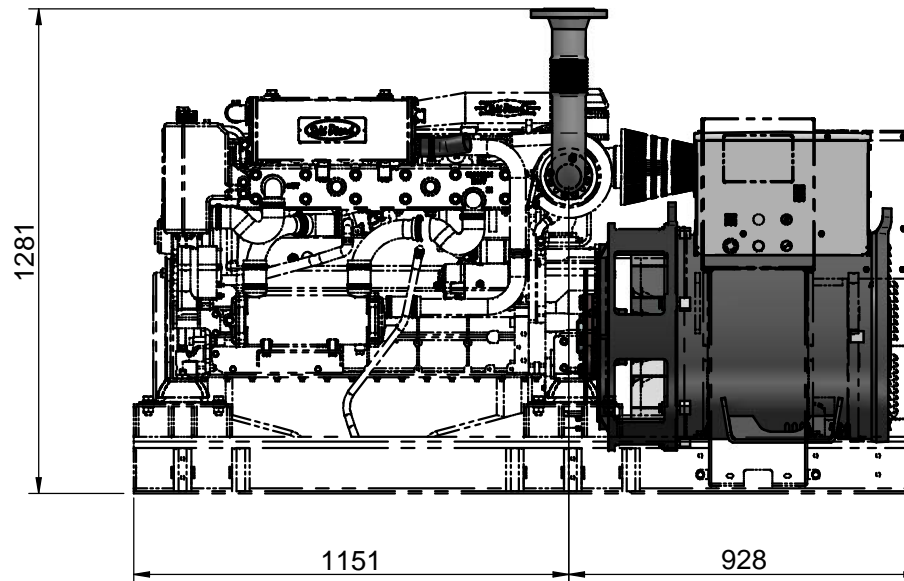

Nº	Referencia	Descripción	Material	Cant.
1	19113119	CODO ESCAPE SECO	Acero	1
2	52103310	DIN-912 M10 x 35	ACERO 8.8	4
3	52120010	TUERCA M10 DIN 934	Acero	4
4	52030010	ARANDELA PLANA Ø10 DIN125 TRATADA	ACERO	4
5*	53033010	ARANDELA GROWER Ø10 DIN-127	Acero	4

Medidas Nominales (mm)		KIT ESCAPE SECO Y FLEXIBLE (S)				
100	a	KIT DRY EXHAUST WITH FLEXIBLE PIPE (S)				
30	a	MATERIAL	ACABADO	TRATAMIENTO	PRESENTACION	ESCALA
6	a	Suavizar Aristas	/.
0	a	DIBUJADO	VERIFICADO	GRADO PRECISION	FECHA CREACION	ULTIMA REVISION
		P.IGLESIAS		MEDIO	30/05/2018	--
Grado de Precisión DIN-7168	Fino	Solé Diesel		SOLÉ, S.A.	19613115	
	Medio					
	Bastio					

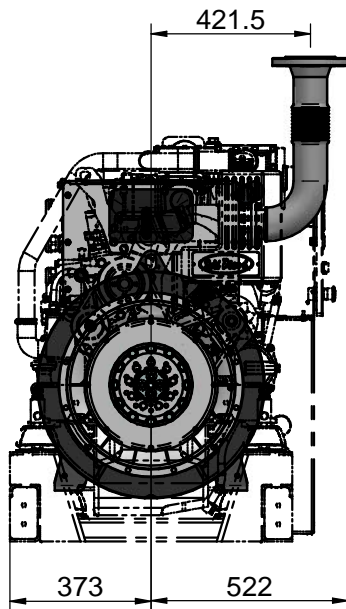

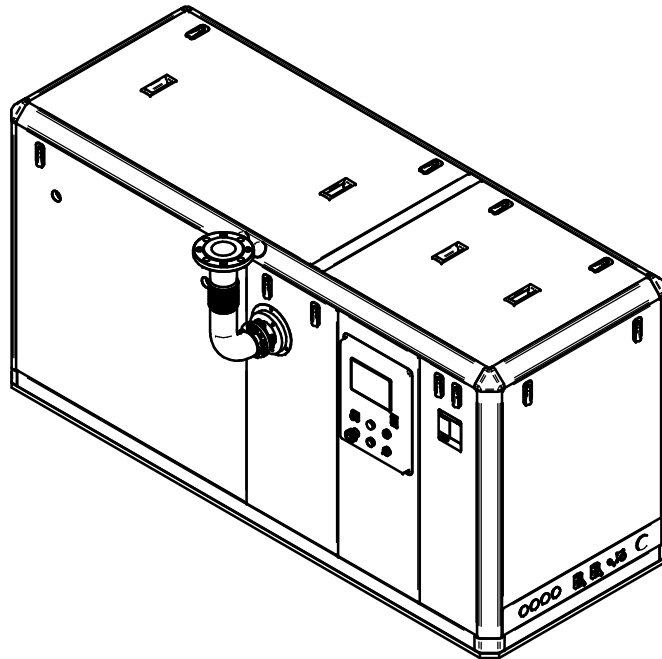
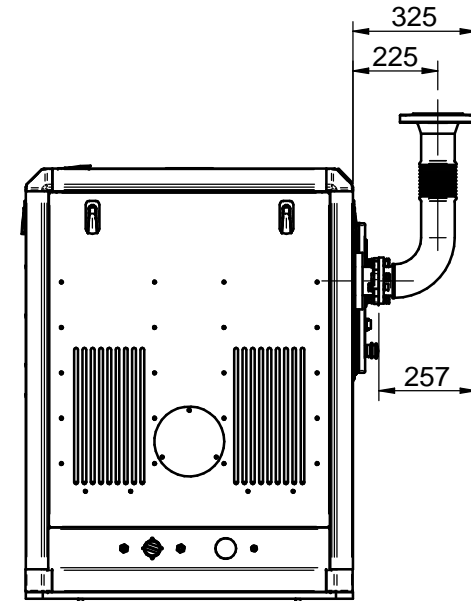
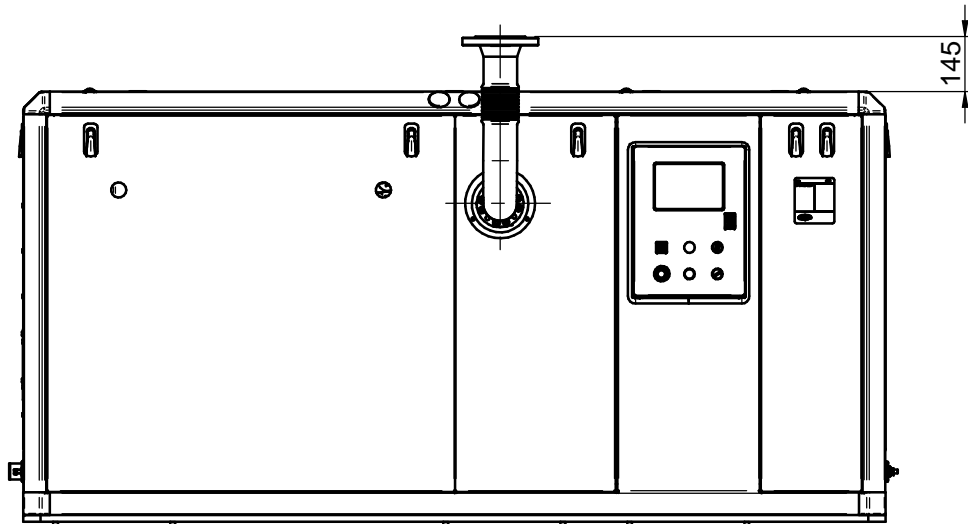
Medidas Nominales (mm)	100	KIT ESCAPE SECO Y FLEXIBLE (S)				
	30 a 300	KIT DRY EXHAUST WITH FLEXIBLE PIPE (S)				
	6 a 30	MATERIAL	ACABADO	TRATAMIENTO	PRESENTACIÓN Suavizar Aristas	ESCALA /.
	0 a 6	DIBUJADO P.IGLESIAS	VERIFICADO	GRADO PRECISIÓN MEDIO	FECHA CREACIÓN 30/05/2018	ÚLTIMA REVISIÓN --
Grado de Precisión DIN-7168	Fino ±0.05 Medio ±0.1 Basto ±0.2			SOLÉ, S.A.	19613115	



Medidas Nominales (mm)	100	KIT ESCAPE SECO Y FLEXIBLE (S)				
	a 300	KIT DRY EXHAUST WITH FLEXIBLE PIPE (S)				
6	a 30	MATERIAL	ACABADO	TRATAMIENTO	PRESENTACIÓN	ESCALA
0	a 6		Suavizar Aristas		/.
Grado de Precisión DIN-7168	Fino	DIBUJADO	VERIFICADO	GRADO PRECISIÓN	FECHA CREACIÓN	ÚLTIMA REVISIÓN
	Medio	P. IGLESIAS		MEDIO	30/05/2018	--
	Bastó			SOLÉ, S.A.	19613115	